



**TECHNICAL
PUBLICATIONS**

RT 8000 Installation and Operation Guide

GJD116, Version 06
Mar 2025

CONTACT AND LEGAL INFORMATION

Visit ORBCOMM Online

www.ORBCOMM.com

Contact Support

Website: <https://www.orbcomm.com/en/support>

Email: customer.care@orbcomm.com OR FMSupport@orbcomm.com (Fleet Management support needs)

Phone: (North America Toll-Free) 1.800.ORBCOMM (United Kingdom Toll-Free) +44 800 538.5909

(USA / International Toll) +1.804.404.8681 (United Kingdom Toll) +44 20 3855.6153

(Australia Toll) +61 (8) 6186 9633

(Austria, Germany, Switzerland Toll) +49 89.208045522

(New Zealand Toll) +64 (9) 884 1439

(Ireland Toll) +353 1.582.4013

Office: 395 W Passaic Street, Suite 325, Rochelle Park, NJ 07662 USA

Export Control Statement

The contents of this document, in whole or in part, shall not be exported from the United States, which export shall include, but not be limited to, transmittal to any non-U.S. citizen wherever said person is located, except in accordance with all United States laws and regulations relating to exports and to all administrative acts of the U.S. Government pursuant to such laws and regulations. Diversion, re-export or transshipment of the contents of this document, in whole or in part, contrary to U.S. law is also strictly prohibited.

Trademark Notice

The ORBCOMM name and the ORBCOMM logo are registered trademarks owned by ORBCOMM LLC or its affiliated companies.

The Bluetooth® wordmark and logos are registered trademarks owned by the Bluetooth SIG, Inc.

Phillips is a trademark of Phillips Screw Company.

Other trademarks, trade names, and logos are those of their respective owners.

TABLE OF CONTENTS

Contact and Legal Information	2
Contact Support	2
Preface	6
Purpose	6
Notation	6
Terminology	6
Cautions and Warnings	6
Battery Safety Warnings	7
Regulations	7
Intended Use Statements	8
WEEE Statement	8
References	8
1 Install the RT 8000 and Peripherals	9
1.1 Identify the Components	9
1.1.1 Product Variants	9
1.1.2 Product Label	10
1.1.3 Internal Battery Pack	11
1.2 Review the Installation Requirements	11
1.3 Install the RT 8000	11
1.3.1 Determine the RT 8000 Mounting Location	11
1.3.2 Attach the Cable Harness	12
1.3.3 Install the RT 8000	12
1.3.4 Connect the Power Supply	12
1.4 Connect and Install the External GPS and External Cellular Antennas	12
1.5 Connect and Install the BLE Antenna	13
1.6 Review the Guidelines and Connect the Peripherals	14
1.6.1 Input / Output Channels	14
1.6.2 Temperature Sensors	15
1.6.2.1 Determine the Mounting Location for the Temperature Sensors	15
1.6.3 Digital Inputs	16
1.6.4 Wireless Sensor Connection	17
1.6.5 Fridge Connection	17
1.6.6 Connect to an External Recorder (Networked Setup)	18
1.6.6.1 Connect a Legacy Euroscan or Carrier Datacold Recorder	18
1.6.6.2 Connect a Transcan Temperature Recorder	18
1.6.6.3 Connect a TouchPrint Temperature Recorder	19

1.6.7 9/12 Volt Output	20
1.6.8 Alarm Output (AO)	20
1.7 Select the SIM Card for Communication	21
1.8 Install and Configure the RT 8000 for an External SIM Card	21
1.9 Secure the Cable Harness Cable Splitter	23
2 Configure the RT 8000 Using DeviceManager	24
2.1 Select a Connection Method	24
2.1.1 Connect with a Field Program Cable over Serial	24
2.1.2 Connect over Bluetooth	24
2.2 Configure the RT 8000	24
2.2.1 Perform Basic RT 8000 Configuration	24
2.2.1.1 Main Settings	25
2.2.1.2 Compartments	26
2.2.1.3 Alarms	27
2.2.1.4 Analog Sensors	28
2.2.1.5 Virtual Temperatures	30
2.2.1.6 Digital Sensors	31
2.2.1.7 I/O	32
2.2.1.8 Fridge	32
2.2.1.9 GPS	33
2.2.1.10 Communication	35
2.2.1.11 Fuel	36
2.2.1.12 Battery	37
2.2.1.13 Wireless Sensors	38
2.2.1.14 Door Locks	38
2.2.1.15 EBS	38
2.3 Configure the Peripherals	39
2.3.1 Perform Basic Network Setup Configuration	39
2.3.1.1 Analog Sensors / Virtual Temperatures Settings	40
2.3.1.2 Digital Sensors Settings	40
2.3.1.3 Communication Settings	41
2.4 Reset the RT 8000 Configuration	42
2.4.1 Configuration Reset Using DeviceManager (Local)	42
2.4.2 Configuration Reset Using Account Manager (OTA)	42
3 Installation Qualification	43
3.1 RT 8000	43
3.2 Communication	43
3.3 Sensors	44

3.4 Peripherals	46
4 Maintenance	48
4.1 Inspection	48
4.2 RMA	48
4.3 RT 8000 Calibration	48
4.4 Remove the RT 8000	49
4.5 Restart the RT 8000	50
4.5.1 Restart Using DeviceManager	50
4.5.2 Restart Using the Reset Pin	50
5 Certification and Compliance	51
APPENDIX A Order Part Numbers	52
APPENDIX B Technical Specifications	54
APPENDIX C RT 8000 LED Description	55
APPENDIX D Temperature Registration and Alarms	56
D.1 Temperature Registration	56
D.2 Alarms	58
APPENDIX E Inclement Weather Installation Guidelines	63
APPENDIX F Cable Harness Wiring Connections	64
APPENDIX G RT 8000 Universal Harness	68

PREFACE

Purpose

This guide contains detailed installation and operation instructions for the RT 8000. The intended audiences for this guide include field support personnel, product evaluators, and certified third-party personnel. It is particularly intended for personnel who are responsible for system installation and activation. In addition, and as is appropriate, this guide may be used for training purposes.

Notation

CAUTION: Indicates an explicit message possibly resulting in injuries, unexpected behavior, or damaged hardware.



Alert

Indicates a message that requires special attention.



A note indicates information with no potential hazard. A note indicates points of interest or provides supplementary information about a feature or task.

Terminology

Term	Definition
Recorder	A device that takes measurements, alone or in conjunction with supplementary devices.
Refrigerator / Reefer / Fridge	A refrigeration unit connected to the RT 8000 over serial (RS-232) or CAN bus.
Temperature sensor	Element of a measurement instrument or measuring chain that is directly affected by the temperature.
Wireless Digital Sensor	A digital sensor, for example, the DS 300, which communicates wirelessly with the recorder over BLE. Refer to the ORBCOMM datasheets for more digital sensor products.
Wireless Temperature Sensor	A temperature sensor, for example, the TS 310. Refer to the ORBCOMM datasheets for more temperature sensor products.

Cautions and Warnings

IMPORTANT

READ ALL INSTRUCTIONS CAREFULLY BEFORE INSTALLING. FAILURE TO DO SO MAY CAUSE PERSONAL INJURY OR DAMAGE TO PRODUCT AND/OR PROPERTY.

- Review the product package and contents prior to beginning the installation. Take care when opening the packaging and removing items. If a return is needed, you will want to return the product in its original packaging if possible. • This instruction guide is provided as a GENERAL installation guide; some assets vary dimensionally and may require additional steps. • ORBCOMM has a policy of continuous development and improvements. Therefore, products, guides, and technical information are subject to change without prior notice. • The manufacturer and / or distributors do not accept responsibility for third-party charges, labor, and / or third-party replacement modifications that are not ORBCOMM approved. Some modifications may void the factory warranty. • ORBCOMM does not accept any responsibility for installations performed by installers / third parties not approved and / or authorized by ORBCOMM. Some installations may void the factory warranty. • Exercise due diligence when installing this product. ORBCOMM does not accept any responsibility for asset damage or personal injury resulting from the installation of this product.

Careless installation and operation can result in serious injury or equipment damage. • All liability for installation and use rests with the owner / operator. • Always make sure you have a clean, dry, and well-lit work area. • Always ensure products are secure during disassembly and installation. • Always take steps to protect yourself when drilling, cutting, and grinding because this may create flying particles that can cause injury. • Thoroughly inspect the area to be drilled, on both sides of material, prior to modification, and relocate any objects that may become damaged. • Always route electrical cables carefully. Avoid moving parts, parts that may become hot and rough, or sharp edges. • Make sure to fully understand the product, its intended use, and operation prior to use.

CAUTION: While ORBCOMM provides mounting hardware to assist with installations, it is the responsibility of the installer to select the proper mounting hardware for the asset's surface material where an ORBCOMM device or accessory will be mounted.

CAUTION: DO NOT use the RT 8000 if it has been physically damaged or appears to be abused.

CAUTION: Never make incorrect polarity connections when connecting the RT 8000 to a power supply. Always verify polarity to make sure the red wire connects to the red wire and the black wire connects to the black wire.

CAUTION: DO NOT work on the installation when the RT 8000 is connected to an external power supply.

CAUTION: Be aware of hazards involved with electrical circuitry and be familiar with standard practices for preventing accidents.

CAUTION: DO NOT modify the RT 8000 in any way.

CAUTION: DO NOT work on the system or connect or disconnect cables during periods of lightning activity.

CAUTION: DO NOT expose the (inside of the) RT 8000 to rain or moisture during installation.

CAUTION: DO NOT install near heat sources such as exhaust pipes.

CAUTION: Only use accessories specified by the manufacturer.

For information regarding liability, warranty, guarantee, and / or service, please refer to your signed (ORBCOMM Customer) Equipment Sales Terms and Conditions contract.

Battery Safety Warnings

CAUTION: The RT 8000 uses a rechargeable lithium battery. DO NOT try to charge with a higher current or a higher voltage than specified, discharge by force, or replace this battery.

CAUTION: Always follow local disposal guidelines to properly dispose of the Lithium-ion battery and the device.

CAUTION: Store in a cool, well-ventilated area. Elevated temperatures will result in shortened battery life.

CAUTION: DO NOT replace the battery. Changing the battery without ORBCOMM's permission could violate regulatory conformity.

CAUTION: DO NOT throw the internal battery or the device into fire.

Regulations

Only ORBCOMM trained and qualified personnel should be allowed to install, replace, or service the RT 8000. The ORBCOMM certified installer needs to perform the installation of the RT 8000 complying with at least the following:

- This installation and operation guide and other relevant documentation provided by the manufacturer.
- WEEE Directive 2012/19/EU
- Traffic regulations of the country of installation and countries in which the RT 8000 will be used.
- Regulations and instructions described in the installation and operation manual of any supplementary devices.
- For full regulations and compliance, refer to section [5 Certification and Compliance](#).

Intended Use Statements

The RT 8000 is designed to safely operate under the following conditions:

- Operating Voltage: 10 to 32 VDC (negative earth), protected against alternator load shedding.
- Operating Temperature Range: -40°C to +85°C (-40°F to +185°F).
 - Back-up battery range: -20°C to +75°C (-4°F to +167°F)
- Storage Temperature Range: -40°C to +85°C¹ (-40°F to +185°F).
- Humidity: 97% relative humidity at 25°C (77°F).
- Designed for placement and mounting outside of a trailer and therefore requires no special ventilation.
- For protection, use a 5 A floating fuse fitted in the positive (+VE) power line as close as possible to the power connection.

Use of the RT 8000 in adverse conditions may void the product warranty.

WEEE Statement

Disposal of this product should be handled according to all national laws and regulations.

The mark shown to the right is in compliance with Waste Electrical and Electronic Equipment Directive 2002/96/EC (WEEE). The mark indicates the requirement NOT to dispose the equipment as unsorted municipal waste, but use the return and collection systems according to local law.



References

The content of the following documents, available from ORBCOMM, may be useful in conjunction with this guide.

[E0003] DeviceManager User Guide

[E0002] ColdChainView User Guide

[AC014] TS 300 Installation Guide

[AC015] TS 310 Installation Guide

[AC016] DS 300 Installation Guide

ORBCOMM Datasheets - Temperature Sensors, TS 310, DS 300, and RT 8000.

¹All individual components are specified for this temperature range.

1 INSTALL THE RT 8000 AND PERIPHERALS

The RT 8000 is available in several variants and is suitable for outside mounting on a trailer. Its connectors are designed for plug and play connection.

CAUTION: Turn the Reefer OFF when servicing and be aware that there may be a temperature change within the refrigerated compartment during servicing that may lead to the loss of the load. ORBCOMM is not liable for lost loads.

CAUTION: Remove the cable from the negative terminal of the Reefer battery and secure the cable to prevent accidental contact before performing any installation or service procedure. Only trained personnel should perform the procedures outlined in this guide. These procedures may allow exposure to high electrical energy that could result in electric shock and injury to untrained personnel during servicing, maintenance, and installation.

CAUTION: Be aware of your working environment. Take appropriate steps to ensure that the RT 8000 harness and especially its connectors are not exposed to soil, water, or other contaminants that may be present at the installation site.

Note: For inclement weather or double-sided tape installations, refer to [APPENDIX E](#).

1.1 Identify the Components

Generally, an RT 8000 ships with all the required components for a standard installation.

1.1.1 Product Variants

There are several variants of the RT 8000, each with specific hardware configuration and connection options. The variant type is indicated on a product label on the RT 8000 and on the shipping box.





RT 8000-1100



RT 8000-2100

CAUTION: Before installing an RT 8000, ensure that you have the correct variant and any required peripherals for the installation. Refer to [APPENDIX A](#) for a list of order part numbers and hardware descriptions.

Variant	# GPIO Connections	# 1-Wire Connections	# RS-232 and RS-232/RS-485 (COM) Connections	# CAN Connections	LTE Antenna Type	GPS Antenna Type	BLE Antenna Type
RT8000-1100	10	1	1 - RS-232 1 - RS-232/RS-485	2	Internal	Internal	Internal and External
RT8000-2100	10	1	1 - RS-232 1 - RS-232/RS-485	2	External	External	Internal and External

1.1.2 Product Label

The product label on the RT 8000 contains important information. The table provides an overview of the information available on the label (order of the information is subject to change).

	Description
Model #	The RT 8000 model number.
FCC ID	The RT 8000 United State’s Federal Communication Commission’s identifier.
IC ID	The RT 8000 Industry Canadian identifier.
Certification and Compliance	An area for applicable certification and compliance labels.
RT 8000 P/N	The RT 8000 product number. Identifies the RT 8000 variant and version.
RT 8000 S/N	The RT 8000 serial number.
IMEI #	The RT 8000 International Mobile Equipment Identity (IMEI).
SIM ID	The Integrated Circuit Card Identification Number (ICCID) of the internal embedded SIM card. This is a unique 18 to 22-digit code.

A QR code, available on the label, which (when scanned) provides the information in a comma separated text string. The information is provided in the following order: RT 8000 S/N, RT 8000 P/N, SIM ID, IMEI #

1.1.3 Internal Battery Pack

The RT 8000 contains a 2000 mAh internal battery pack that enables it to store and report data for a limited time when external power is unavailable. The RT 8000 automatically switches to the internal battery pack when external power is unavailable and charges the pack when (sufficient) external power is available.

CAUTION: If the battery is too cold ($\leq 0^{\circ}\text{C}/32^{\circ}\text{F}$) or too hot ($\geq 45^{\circ}\text{C}/113^{\circ}\text{F}$), on-board software keeps it from charging to avoid damaging the battery.

The red power LED on the RT 8000 identifies the status of the internal battery pack usage. Refer to [APPENDIX C](#) for more information.

1.2 Review the Installation Requirements

Ensure you have the following functional and installation requirements before you begin:

- Power supply 10 to 32 VDC (negative earth)
- (International traceable) calibration equipment
- Appropriate working tools for the installation
- Supplementary mounting materials (like sealant (accepted by the food and pharma industry), cable trunking, and fixing materials for cable mounting)
- Latest version of the DeviceManager software package with sufficient permissions for any installation.

1.3 Install the RT 8000

CAUTION: Wiring should be free of obstacles, kinks, sharp bends, or dents. The use of a wiring loom is recommended to prevent damage to the cable (that is, due to vibration).

1.3.1 Determine the RT 8000 Mounting Location

If mounting the RT 8000 outside directly on the vehicle body, the RT 8000 does not require a bracket. Usually, it is fixed under the side doors of the refrigeration unit.

Figure 1: Example of an Installation Location on a Trailer



Figure 2: Example of an Installation Location on a Truck



1.3.2 Attach the Cable Harness

To ensure that you have enough cable length for the installation, temporarily attach the cable harness to the asset based on where you decided to mount the RT 8000.

1. Use double-sided tape or a similar method to temporarily mount the cable splitter of the cable harness. Ensure that the mount is stable and remains in place during the installation process.

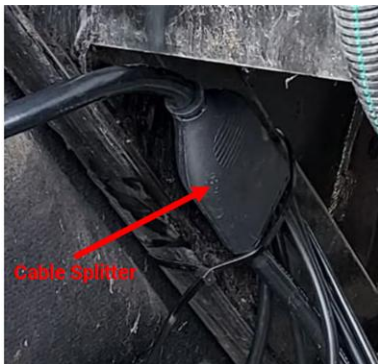

2. Connect one end of the cable harness to the RT 8000.

1.3.3 Install the RT 8000

RT 8000 installations can vary by customer. Ensure that you follow all the recommended installation guidelines, take care not to damage the vehicle or cargo when drilling holes in the asset, and that you seal any drill holes.

1.3.4 Connect the Power Supply

1. Connect the power supply directly to the vehicle or refrigerator battery. Fit the included 5 A (T) floating fuse in the +power line as close as possible to the power connection.

The RT 8000 is suitable for a voltage between 10 to 32 Volts DC.

1.4 Connect and Install the External GPS and External Cellular Antennas



This section only applies to RT 8000 variants with an external GPS or cellular antenna connection.

- CAUTION:**
- DO NOT let the antenna hang on the connection cable.
 - DO NOT mount the antenna and wiring close to a heat source (like heating channels or exhaust pipes).
 - DO NOT cut, extend, or make any changes to the cables.
 - DO NOT curl up the cables.
 - DO NOT bend the cables in sharp angles as this might break the core of the wire.
 - DO NOT place the antenna too close to toll systems.
 - Make sure that the antenna has a clear view to the sky (towards the satellites).
 - Place cables into a cable gutter.
 - Install the antenna according to the installation standards (and not directly in the drivers view).
 - DO NOT choose a location covered by metal, metal containing components, or paint.

CAUTION: ESD Caution: Connect the RT 8000 to power before connecting the antennas.



Testing of the GPS signal is not the same as reception on smartphones. Smartphones use the assisted GPS technology, but location detection uses cell towers and Wi-Fi.

1. Connect the antenna cables to the connections on the back of the RT 8000. The connections shown in the figure vary by RT 8000 model.



2. Install the antennas ensuring that you follow the mounting guidelines.

1.5 Connect and Install the BLE Antenna



This section only applies to RT 8000 variants with an external BLE antenna connection.

1. Connect the antenna cable to the connection on the back of the RT 8000. The connections shown in the figure vary by RT 8000 model.



If the RT 8000 does not use any wireless sensors, there may be no need to connect a BLE antenna. In this case, cover the BLE antenna connector with a universal waterproof cap / plug (available from ORBCOMM - part number CON100367 - FAKRA Z-code waterproof male connector plug) to prevent water ingress.

2. Mount the external BLE antenna on the roof / ceiling inside the trailer compartment to ensure proper connectivity with wireless sensors.



1.6 Review the Guidelines and Connect the Peripherals

This section identifies the various peripherals, including sensors, and provides installation guidelines for each.

Note: Refer to [APPENDIX F](#) for wiring details on where to connect each peripheral to the cable harness.

1.6.1 Input / Output Channels

The RT 8000 supports up to 10 assignable GPIO (General Purpose Input / Output) cables, which allows connection to a maximum of 10 temperature sensors, or 10 digital contacts, or any combination of these up to 10. Refer to section [2](#) to configure the RT 8000.

CAUTION: The number of GPIO connections available depends on the RT 8000 variant and selected cable harness. Refer to section [1.1.1](#) for more information.

1.6.2 Temperature Sensors

The RT 8000 works with several ORBCOMM temperature sensors. Refer to the ORBCOMM Temperature Sensors [datasheet](#), available from ORBCOMM, for more details.

Type	Temperature Range	Accuracy	Length	Part Number	Price List Name
Temperature Standard	-50°C to +70°C (-58°F to +158°F)	0.1°C	6 m	009.000.5106	TEMP. SENSOR 6m IN METAL HEAD 70°C ACC. 0.1°C
			15 m	009.000.5115	TEMP. SENSOR 15m IN METAL HEAD 70°C ACC. 0.1°C
			22 m	009.000.5122	TEMP. SENSOR 22m IN METAL HEAD 70°C ACC. 0.1°C
Temperature Standard with Connector		0.1°C	3 m	009.000.5103	TEMP. SENSOR 3m IN METAL HEAD 70°C W CONN AND C.CONN
Temperature Standard		0.2°C	6 m	009.000.5006	TEMP. SENSOR 6m IN METAL HEAD 70°C
			15 m	009.000.5015	TEMP. SENSOR 15m IN METAL HEAD 70°C
	22 m		009.000.5022	TEMP. SENSOR 22m IN METAL HEAD 70°C	
Glycerin Probe	0.2°C	12 m	009.001.0003	TEMP. SENSOR GEL 12 MTR. METAL TUBE 70°C	

1.6.2.1 Determine the Mounting Location for the Temperature Sensors

Before installation, determine how many measurement points are required to retrieve the desired information. The better you plan the position and number of sensors, the better data they can collect about the air temperature in the compartment.

Follow the guidelines below during your planning:

- **DO NOT** mount the temperature sensor in a location without air circulation.

CAUTION: The maximum temperature range of the sensor is at risk when mounting a sensor too close to the supply air. The range for the sensor is -50°C to +70°C (-58°F to +158°F).

- Protect the sensor position against bumping of load, doors, etc.
- Ensure the channel of the interior light has a minimum distance of 0,5 m (1.6 ft.) to the sensors.
- Ensure you have at least one sensor per compartment and one sensor in the return air. The best position for a compartment sensor is in the middle under the ceiling at about 1/3 of the compartment length, counted from the back.
- Allow enough spare cable to enable the sensor to be lowered to the floor to consider any future calibration requirements.
- Use a spiral or loom around the excess wiring, curl and tie it up to prevent damage to the wiring of the temperature sensor.
- Mount the compartment sensor with the ORBCOMM protection guard (p/n 002.000.0020), which is a cage to protect the sensor and allows sufficient air circulation around the sensor.

To mount the compartment sensor:

1. Verify that you have all the provided mounting materials.



2. Place the isolation material of the sensor in the cleat.



3. Mount the sensor cleat to the guard using the supplied screw, washer and nut.



CAUTION: When cleaning the trailer, be careful with pressure washers and corrosive cleaning supplies, which may damage the temperature sensor. Damage to the sensor may lead to water ingress in the long term, which negatively impacts the life expectancy and temperature measurements of the sensor.

1.6.3 Digital Inputs

The digital inputs allow monitoring and registration of digital signals. Configuring the parameters helps you to interpret the corresponding status. Refer to the "Asset Details" section in document [\[E0002\]](#).

The RT 8000 works with up to 10 external digital contacts.

There are three ways of connecting door switches or other digital signals:

- Standard switch contact on digital input (low)



- Switched to battery (+) (high)



- Switched to ground (-) (low)

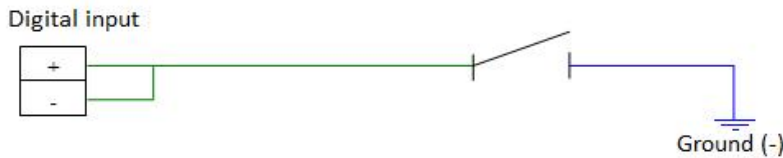

! Digital input distinct between high levels and low levels around 5 V. A voltage level <0.495 V is low level, and >1.625 V is high level. The maximum voltage allowed for the 10 I/O pins is 32 V.

The following door switches, available from ORBCOMM, work with the RT 8000.

Type	Polarity	Length	Part Number	Price List Name
Back Door Switch	Normally Open	22 m / 72 ft	009.001.0050	BACK DOOR SWITCH KIT (MAGNETIC, 22 M CABLE)
Side Door Switch	Normally Open	22 m / 72 ft	009.001.0060	SIDE DOOR CONTACT KIT (MAGNETIC, 22 M CABLE)

1.6.4 Wireless Sensor Connection

You can connect the RT 8000 directly to wireless ORBCOMM temperature and digital sensors (for example, TS 300 (p/n ST100643-001) TS 310 (p/n ST100643-002), and DS 300 (p/n ST100687-001)) to allow more versatile sensor placement. Refer to the related [installation guides](#) for more details.

! A security key is exchanged between the RT 8000 and wireless sensors during their first connection. This security key ensures that the data from the TS 300/TS 310 and DS 300 sensors are encrypted and cannot be modified from external sources.

You cannot change the security key of these sensors once set. After the first successful connection with the RT 8000, the sensors are locked into the current setup.

1.6.5 Fridge Connection

You can connect the RT 8000 to several different types of fridges. Remember to enable the correct communication protocol in the configuration of the RT 8000 to establish connection between the recorder and the fridge. You may also need to enable a setting in the fridge controller. For example, "DataTrack enabled for Carrier fridges".

Compatible refrigeration systems are (but not limited to):

- Carrier
- Mitsubishi

You can connect the fridge (controller) to the RT 8000 via either a serial communication port (COM) or a CAN port, depending on the make and type of fridge.

1.6.6 Connect to an External Recorder (Networked Setup)

You can connect the RT 8000 to an additional external recorder (for example, a legacy Euroscan temperature recorder) to create a networked setup. With a networked setup, it is possible to provide unique features of one recorder to another. The RT 8000 supports the mapping of temperature sensors and digital sensors only.

Note To correctly share recorder specific features, contact your distributor or [Contact Support](#) for configuration instructions.

1.6.6.1 Connect a Legacy Euroscan or Carrier Datacold Recorder

! When connecting the RT 8000 to an external Euroscan or Carrier recorder with a modem (for example, an MX2 or an X3 with modem module installed), then you must first disable the modem of the external recorder. To do this, change the COM4 protocol of the legacy recorder to "No Protocol".

! Ensure that the external recorder is powered OFF before connecting it to the RT 8000.

You can connect an external legacy Euroscan or Carrier Datacold recorder to the RT 8000 over a serial cable connection. You can order an ORBCOMM cable (p/n 004.000.0070 - cable RT 8000/MX2 UCP 3-wire) for this purpose.

Attach the cable (p/n 004.000.0070) to the connector block 5-way (p/n 005.000.0005, included in the mounting set of the X3 product) as shown in the following table.

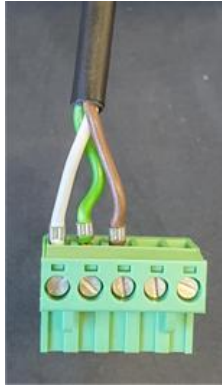
Delphi Connector Pin	Connector Block 5-Way Pin	Cable Color	Function
		Note The cable color on the product may vary from the example shown here.	-
C	1	White	GND
B	3	Brown	TX
A	2	Green	RX

1.6.6.2 Connect a Transcan Temperature Recorder

! Ensure that the Transcan temperature recorder is powered OFF before connecting it to the RT 8000.

You can connect an Addsecure Transcan temperature recorder to the RT 8000 over a serial cable connection. You can order an ORBCOMM cable (p/n 004.000.0070 - cable RT 8000/MX2 UCP 3-wire) for this purpose.

Attach the cable (p/n 004.000.0070) to the Transcan temperature recorder connector block as shown in the following table.

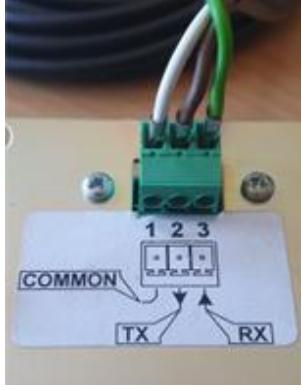
Delphi Connector Pin	Transcan Connector Block	Cable Color	Function
		Note The cable color on the product may vary from the example shown here.	-
C	1	White	GND
B	2	Brown	TX
A	3	Green	RX

! When the temperature sensor mapped from the Transcan recorder shows a constant temperature value of +50°C (+122°F), this indicates that there is an issue with the Transcan recorder sensor. Check the temperature sensors connected to the Transcan recorder.



For more information, contact your Transcan supplier or refer to the associated Transcan installation guide.

1.6.6.3 Connect a TouchPrint Temperature Recorder

! Ensure that the TouchPrint temperature recorder is powered OFF before connecting it to the RT 8000.

You can connect a Thermo King TouchPrint temperature recorder to the RT 8000 over a serial cable connection. You can order an ORBCOMM cable (p/n 004.000.0070 - cable RT 8000/MX2 UCP 3-wire) for this purpose.

Attach the cable (p/n 004.000.0070) to the TouchPrint temperature recorder connector block as shown in the following table.

Delphi Connector Pin	TouchPrint Connector Block (right to left)	Cable Color	Function
		Note The cable color on the product may vary from the example shown here.	-
C	3	White	GND
B	1	Brown	TX
A	2	Green	RX

On the TouchPrint, ensure that a constant connection exists between pins 2 (+) and 3 (Key) to avoid the device going into sleep mode. For more information, refer to the TouchPrint installation guide (available from Thermo King).

1.6.7 9/12 Volt Output

The output wires labeled "9V / 12V" (brown and black) on the cable harness (refer to [APPENDIX F](#)), outputs a continuous (unswitched) output voltage, which is limited to 500 mA (0.5 A).

1.6.8 Alarm Output (A0)

The output wire labeled "Alarm" (yellow) on the cable harness (refer to [APPENDIX F](#)), is a digital alarm output. In an alarm situation, the output switches to ground and is limited to 1 A output current.

Option 1 - Direct Connection

Note The alarm output is only triggered when a temperature or digital contact alarm is triggered on the RT 8000. The alarm output does not trigger on a low battery alarm or when relaying an alarm from a connected peripheral (for example, when a fridge registers an alarm event, alarm output is not triggered).

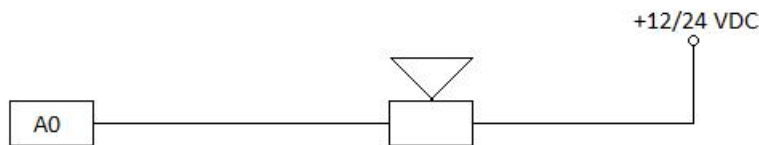

Option 2 - Toggle Connection

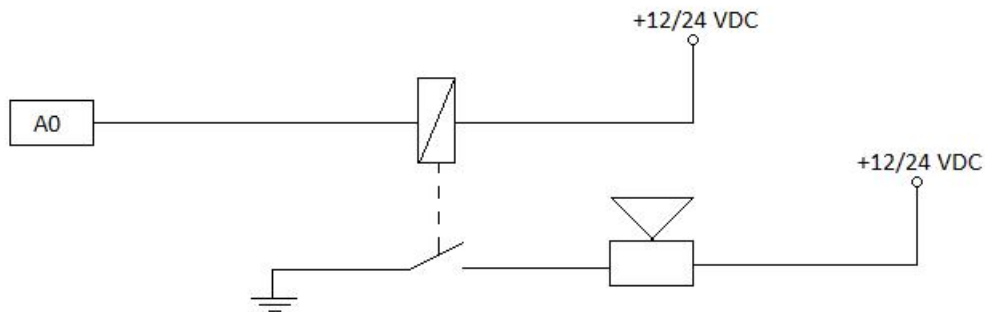

CAUTION: Option 2 is recommended when an alarm is chosen that has peak currents greater than 1 A.

1.7 Select the SIM Card for Communication

The RT 8000 includes an internal embedded SIM card and has an optional slot for an external SIM card.

To select the SIM card used for communication:

1. Connect the RT 8000 to the DeviceManager software.
2. In DeviceManager, select the **Configuration** menu, and then navigate to the **Communications** tab.
3. Select the **iGPRS** sub-tab, in the **SIM Source** field, select the SIM card to use.
 - Embedded SIM
 - External SIM = external SIM card; refer to section 1.8 for details on how to install and configure the device for an external SIM card.
4. From the **Install & Maintenance** menu, select the **Reboot Device** command to restart the RT 8000.
5. From the **Device Information** menu, check the **Online Info** box to verify that the RT 8000 has a connection to the server.

1.8 Install and Configure the RT 8000 for an External SIM Card



Verify that

- you have an activated SIM card that supports GPRS data in the micro-SIM form factor
- the SIM card works before installation
- you have the specific APN settings for the SIM card and if applicable the correct pin code

1. Open the SIM card door by unscrewing the two Philips screws.



2. Install the SIM card in the orientation shown in the figure.



3. Connect the RT 8000 to the DeviceManager software.
4. In DeviceManager, select the **Configuration** menu, and then navigate to the **Communications** tab.
5. Select the **iGPRS** sub-tab, and then select SIM Source "**External SIM**".
6. In the **APN server** field, select the APN server that corresponds to the SIM card you are installing. • Verify that the information in the APN Server Address, APN Username, and APN Password match the information provided by the SIM card supplier.
7. (optional) If your desired APN server is not available from the drop-down list, or if the settings from the APN server preset do not match with the settings provided by the SIM supplier, manually enter the following (if applicable):
 - APN Server Address
 - APN Username
 - APN Password
8. (optional) If your SIM card is locked with a pincode, type the pincode in the SIM Pincode setting.
9. From the **Install & Maintenance** menu, select the **Reboot Device** command to restart the RT 8000.
10. From the **Device Information** menu, check the **Online Info** box to verify that the RT 8000 has a connection to the server.

1.9 Secure the Cable Harness Cable Splitter

CAUTION: You MUST restrain the cable splitter to avoid damage.

1. Remove the cable splitter from the asset surface, and then remove the double-sided tape or similar material.
2. Use one or more of the recommended methods below to affix the cable splitter to the asset:

CAUTION:

- Double-sided tape
 1. Use a scour pad to prepare the asset surface area for bonding (ensure that an oversized area is prepared).
 2. Clean the surface with an alcohol cleaner or wipe, and then allow the surface to dry.
 3. Apply 3M Primer to the area and wait at least 30 seconds for the primer to dry. Refer to [APPENDIX E Inclement Weather Installation Guidelines](#).
 4. Remove the tape liner from the cable splitter.

CAUTION: DO NOT touch the double-sided tape.

5. Press firmly on the cable splitter (7 kg (15 pounds) for 60 seconds) to bond the tape to the asset.
- Cable ties or zip ties (ensure that the cable splitter does not vibrate / move)
 - Another ORBCOMM approved method

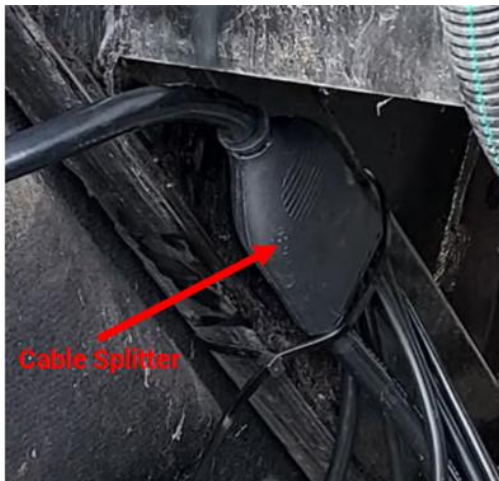

2 CONFIGURE THE RT 8000 USING DEVICEMANAGER

Use DeviceManager to configure the RT 8000. Refer to section 2.1 or document [\[E0003\]](#) for connection options.

Note You can also remotely configure the RT 8000 using Account Manager if the RT 8000 is connected to the ColdChainView server. The menus and configuration options described in this section also apply for remote configurations when using Account Manager.

2.1 Select a Connection Method

There are several connection options available to connect the RT 8000 to DeviceManager.

Note To correctly share recorder specific features, contact your distributor or [Contact Support](#) for configuration instructions.

2.1.1 Connect with a Field Program Cable over Serial

Use a field-programming cable (p/n 004.001.0026) to connect over the RT 8000 connector (COM1) to an RT 8000 via the harness cable.

2.1.2 Connect over Bluetooth

The RT 8000 has a built-in Bluetooth module. With this communication option DeviceManager can wirelessly connect to it over Bluetooth.

To use Bluetooth, you require the following:

- A computer / laptop with Windows 7 or newer.

Note Computers with Windows 7 may need BLE specific drivers installed before you can establish a connection to the RT 8000 .

- A ORBCOMM certified Bluetooth dongle (ORBCOMM p/n 009.002.0070).
- The latest version of DeviceManager.

 While connected to the RT 8000 over Bluetooth, all other Bluetooth related communication is temporarily halted.

 The connection between the RT 8000 and DeviceManager locks one of the eight available BLE channels on the RT 8000. If the RT 8000 is configured with eight wireless sensors, then it cannot communicate with all eight sensors and DeviceManager over Bluetooth simultaneously.

Refer to the "Bluetooth Dongle Installation" chapter, and the "Connect DeviceManager to a Device" chapter in document [\[E0003\]](#) for more details.

2.2 Configure the RT 8000

This section describes the parameters and functions you can set from the DeviceManager Configuration menu. Refer to section 2.3 to configure peripherals.

2.2.1 Perform Basic RT 8000 Configuration

The DeviceManager Configuration menu ( Configuration) includes the sub-menu items in the list below. To complete a basic configuration, check all underlined items before continuing with the Installation Qualification chapter.

- [Main Settings](#)
- Compartments
- Alarms
- [Analog Sensors](#)
- [Virtual Temperatures](#)
- [Digital Sensors](#)
- [I/O](#)
- Fridge
- GPS
- [Communication](#)
- Fuel
- Battery
- Wireless Sensors
- Door Locks
- EBS

2.2.1.1 Main Settings

1. From **Main Settings**, select **Change Configuration** to edit general RT 8000 information and settings.

The screenshot shows a configuration window with the following fields and values:

- Vehicle name:** RT8000_Support
- Customer ID:** 71000195
- Sensor Measure interval:** 10 Minutes
- Copy Trailer ID:**
- Time synchronisation source:** Synchronize with GPS
- Pincode:** 1111

Vehicle name:	Identifies the RT 8000. Edit this title with a better description to identify the RT 8000. By default, the Vehicle name is the serial number followed by the product type. For example, xxxxxxxxRT8.
Copy Trailer ID:	Automatically replaces the Vehicle name with the name of a connected peripheral. For example, replace the Vehicle name with the name of a connected Fridge unit.

Customer ID:	Allows you to assign an RT 8000 directly to a customer account on the ColdChainView server. CAUTION: Ensure you have the correct Customer ID before modifying this field. This is an 8-digit number.
Sensor Measure interval:	The interval between each temperature measurement. A value between 1 and 60 minutes. CAUTION: There are no periodic temperature measurements when setting the interval to 0 minutes
Time Synchronisation source:	Allows you to set the source for time synchronization. * No synchronization - Disables this functionality * Synchronize with UCP Server -Uses the server time of the connected platform * Synchronize with GPS (default) - Uses the information received from GPS
Pincode:	Allows you to set the RT 8000 pincode. You need the pincode to access the parameter menu directly from the RT 8000. Changing the pincode enhances security. For more information, please refer to document [E0003].

2.2.1.2 Compartments

Compartments group various sensors together. From the compartment’s menu, you can enable and disable compartments and assign alarm groups to a compartment.

The screenshot shows a configuration interface for compartments. It lists four compartments, each with a checkbox for 'On' status, a text input field for 'Compartment Name', and a dropdown menu for 'Alarmgroup'. The first compartment is checked and named 'Compartment 1'. The other three are unchecked and named 'Compartment 2', 'Compartment 3', and 'Compartment 4' respectively. All 'Alarmgroup' dropdowns are set to 'No alarmgroup'.

Compartment X On:	Allows you to enable or disable the compartment. CAUTION: If the compartment is disabled; Alarm monitoring is not active for the analog sensors in the compartment, even if an Alarmgroup is assigned.
Compartment Name:	Allows you to set the name of the compartment used on the ColdChainView server.
Alarmgroup:	Allows you to choose the alarm group assigned to the compartment. The alarm groups must be enabled and configured on the Alarms tab. Refer to section 2.2.1.3 for more information about alarm groups.

2.2.1.3 Alarms

Use alarm groups to set alarm thresholds for analog sensors connected to a compartment. The Alarms menu is divided into sub-tabs, General Settings covers settings for every alarm group, and multiple Alarm X tabs cover settings for individual alarm groups.

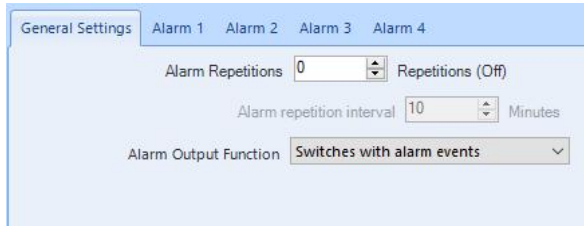

Alarm Repetitions:	This feature is not available for the RT 8000.
Alarm repetition interval:	This feature is not available for the RT 8000.
Alarm Output Function:	Allows you to set the function of the alarm output (AO): - <i>Switches with alarm events</i> activates an external device (sound or light) in case of an alarm. - <i>Switched with external commands</i> starts or stops a connected fridge unit.

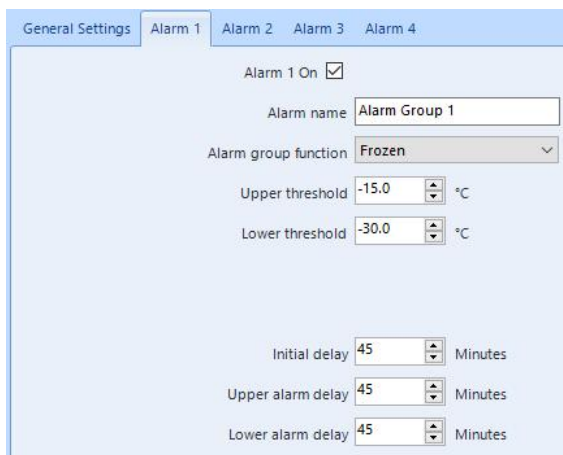

Alarm X On:	Allows you to enable or disable an alarm group. CAUTION: Even if the alarm group is enabled, you must assign the alarm group to a compartment to be monitored. Refer to section 2.2.1.2 for more information about compartments.
Alarm name:	Allows you to add a name for the alarm group.
Alarm group function:	Allows you to select a general function for the alarm group (read-only).
Upper threshold:	Allows you to set the upper limit for temperatures before the activation of the alarm.
Lower threshold:	Allows you to set the lower limit for temperatures before the activation of the alarm.
Initial delay:	Allows you to set an initial delay before monitoring the sensors whether an alarm condition is fulfilled. This setting ignores alarms, for example, when an RT 8000 starts before the compartment reaches the Set Point temperature.

Upper alarm delay:	Allows you to set the time limit before the activation of an alarm when the upper threshold has been exceeded.
Lower alarm delay:	Allows you to set the time limit before the activation of an alarm when the lower threshold has been exceeded.

Note For more information about temperature registration and alarms, refer to [APPENDIX D](#).

2.2.1.4 Analog Sensors

From the Analog Sensors menu, you can configure the Analog Sensors connected to the RT 8000 or map the temperature information from external sources to the RT 8000.

For each temperature record written to the memory of the RT 8000, it checks 20 temperature records and stores them based on the settings of the sensor. For example:

- Sensor measure interval = 1 minute: temperature sample taken every 3 seconds.
- Sensor measure interval = 5 minutes: temperature sample taken every 15 seconds.
- Sensor measure interval = 10 minutes: temperature sample taken 30 seconds.

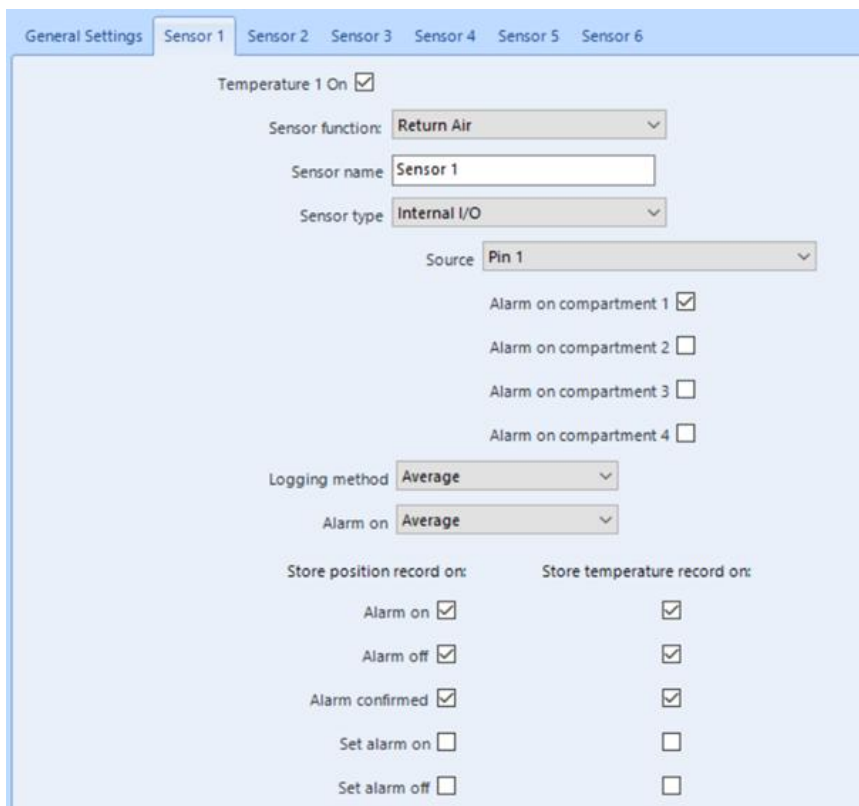

Temperature X On:	Allows you to enable or disable a sensor. CAUTION: Disabling a sensor stops recording / logging and alarm monitoring for the selected sensor.
--------------------------	---

Sensor function:	Allows you to select a general function for the sensor (read-only).
Sensor name:	Allows you to set the name of the sensor used on the ColdChainView server.
Sensor type:	<p>Allows you to set the sensor type to function as data input.</p> <ul style="list-style-type: none"> * Source: Retrieves the temperature data from an external device (for example, a Euroscan X3 in a networked setup). * Fridge: Retrieves the temperature / humidity sensor data from a sensor connected to a fridge. * Internal I/O: Retrieves the temperature data from a general purpose I/O channel. * Wireless Sensor: Retrieves the temperature data from a wireless sensor channel.
Source:	<p>The input from which the data is mapped. The available options depend on the selected Sensor Type.</p> <p>Note ► Setting the sensor type to “Fridge” and Source to “Humidity Sensor” changes the unit of measurement from °C/°F to %.</p>
Alarm on compartment X:	<p>The sensor compartment to monitor for alarms.</p> <p>CAUTION: To prevent unexpected behavior, DO NOT select more than one compartment for each sensor.</p>

Logging method:	<p>Allows you to choose the temperature recording type.</p> <ul style="list-style-type: none"> * Off: Does not log temperature records for this sensor. * Average (default): Logs the average of the 20 temperature values as a record.
Alarm on:	<p>Allows you to set the temperature alarm condition type.</p> <ul style="list-style-type: none"> * Average (default): Alarm condition based on the average of 20 temperature values. * Actual: Alarm condition based on the last measured temperature value.

2.2.1.4.1 Set Up an Alarm for an Analog Sensor

To set up an alarm for an Analog Sensor, verify the following settings:

- On the Analog Sensors menu:
 - The Analog Sensor is enabled, (*Temperature X On* is selected).
 - The Analog Sensor is assigned to a single compartment for alarm monitoring, (*Alarm on compartment X* is selected).
- On the Compartments menu:
 - The Compartment where the sensor is assigned is enabled, (*Compartment X On* is selected).
 - An Alarm Group is assigned to the Compartment (*Alarmgroup* should not be set to "No alarmgroup").
- On the Alarms menu:
 - The Alarm Group where the compartment is linked is enabled, (*Alarm X On* is selected).
 - Initial Delay, Upper Alarm Delay and Lower Alarm Delay are set to a value greater than 0.
 - Upper Threshold and Lower Threshold are set to the maximum and minimum allowed temperatures respectively.

If all above settings are correctly set up, an internal alarm triggers as soon as the temperature of the sensor is outside of the bounds (created by the alarm group thresholds) for the specified period (defined by either the upper or lower alarm delay, depending on the exceeded threshold), which is then sent to the ColdChainView server. This alarm is not audible from the RT 8000.

Note For more information about temperature registration and alarms, refer to [APPENDIX D](#).

2.2.1.5 Virtual Temperatures

Virtual sensors allow you to map the temperature information of sensors connected via an external source to the RT 8000.

CAUTION: You cannot monitor the data obtained from sensors mapped to the virtual sensor for alarm situations.

Note As with the analog sensors, for each temperature record written to the memory of the RT 8000, it checks 20 temperature samples and stores them based on the settings of the sensor.

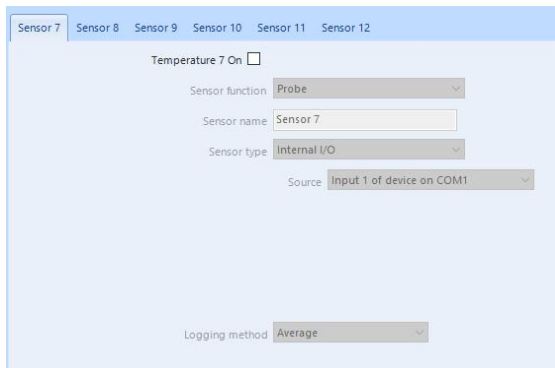

Temperature X On:	Allows you to enable or disable a sensor. CAUTION: Disabling a sensor stops recording / logging data for the selected sensor.
--------------------------	---

Sensor function:	Allows you to select a general function for the sensor (read-only).
Sensor name:	Allows you to set the name of the sensor used in ColdChainView.
Sensor type:	Allows you to set the sensor type that will function as data input. * Source: Retrieves the temperature data from an external device (for example, a Euroscan X3 in a networked setup). * Fridge: Retrieves the temperature / humidity sensor data from a sensor connected to a fridge. * Internal I/O: Retrieves the temperature data from a general purpose I/O channel. * Wireless Sensor: Retrieves the temperature data from a wireless sensor channel.
Source:	Allows you to set the input from which the data must be mapped. Note Setting the sensor type to "Fridge" and Source to "Humidity Sensor" changes the unit of measurement from °C/°F to %.

Logging method:	<p>Allows you to choose the temperature recording type.</p> <ul style="list-style-type: none"> * Off: Does not log temperature records for this sensor. * Average (default): Logs the average of the 20 temperature values as a record.
------------------------	---



For more information about temperature registration and alarms, refer to [APPENDIX D](#).

2.2.1.6 Digital Sensors

The Digital Sensors menu allows you to configure the digital sensors connected to the RT 8000 or map the digital information from external sources to the RT 8000.

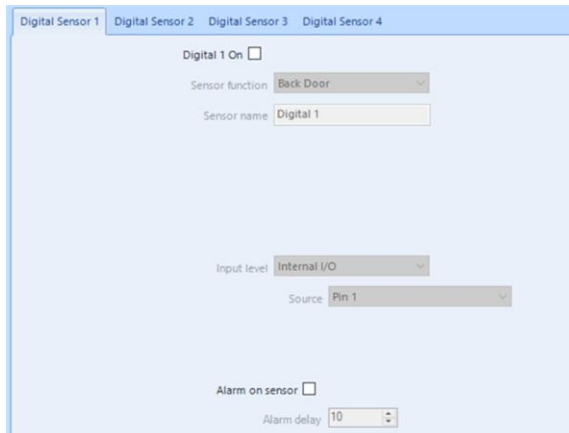

Digital X On:	<p>Allows you to enable or disable a sensor.</p> <p>CAUTION: Disabling a sensor stops recording / logging data and disables alarm monitoring for the selected sensor.</p>
Sensor function:	<p>Allows you to select a general function for the sensor.</p> <p>By changing the function, the icon in ColdChainView changes accordingly.</p>
Sensor name:	<p>Allows you to set the name of the sensor used in ColdChainView.</p>
Input level:	<p>Allows you to set the input level of the digital. The state of the digital can be compared to:</p> <ul style="list-style-type: none"> * Sensor connected to the RT 8000 harness: Internal I/O * Wireless sensor connected to the RT 8000 via BLE: Wireless Sensor * Copy the state of a digital input from an external device: Source * Copy the state of a digital input from a connected fridge: State of Digital 1 to 4 (availability depends on fridge); Pretrip status or Defrost status. * Copy the state of an input from a connected Doorlock: Doorlock Door State or Doorlock Lock State
Source:	<p>Allows you to set the input from which the data must be mapped.</p>
External sensor:	<p>Allows you to set the input from which the data must be mapped. The available options depend on the selected Input level</p>
Alarm on sensor:	<p>Allows you to enable or disable the alarm monitoring on a sensor.</p>
Alarm delay:	<p>Allows you to set a delay, in minutes, before the digital alarm activation.</p>

2.2.1.7 I/O

The I/O menu allows you to configure the function of the 10 general purpose I/O (GPIO) channels of the RT 8000 harness cable.

Note The GPIO number matches the label of the sensor cable on the harness. For example, "GPIO 1" refers to the cable with label "Sensor 1", "GPIO 2" refers to the cable with label "Sensor 2", etc.

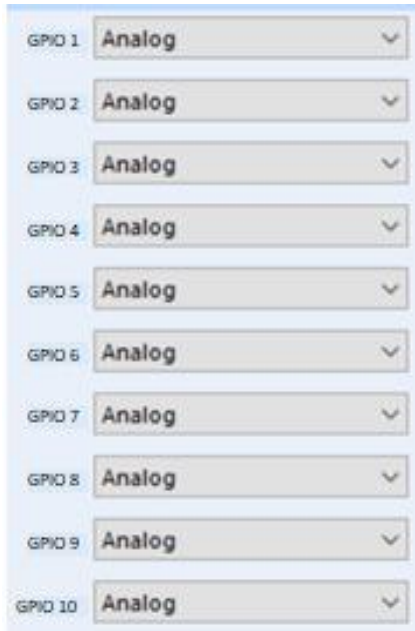

GPIO X:	<p>Allows you to enable or disable a GPIO channel and assign its functionality.</p> <ul style="list-style-type: none"> * None: Disables the general purpose I/O (GPIO) channel. * Digital Active on High: <ul style="list-style-type: none"> • Treats the GPIO channel as a digital input. • Digital Contact closed = input active and open = input inactive. Alarm is switched on Low level. * Digital Active on Low: <ul style="list-style-type: none"> • Treats the GPIO channel as a digital input. • Digital Contact closed = input inactive and open = input active. Alarm is switched on High level. * Analog: Treats the GPIO channel as an analog input.
----------------	---

2.2.1.8 Fridge

The Fridge menu allows to configure the alarm group thresholds based on the set points of a connected fridge.

CAUTION: To use this feature, ensure a fridge unit is connected to the RT 8000.

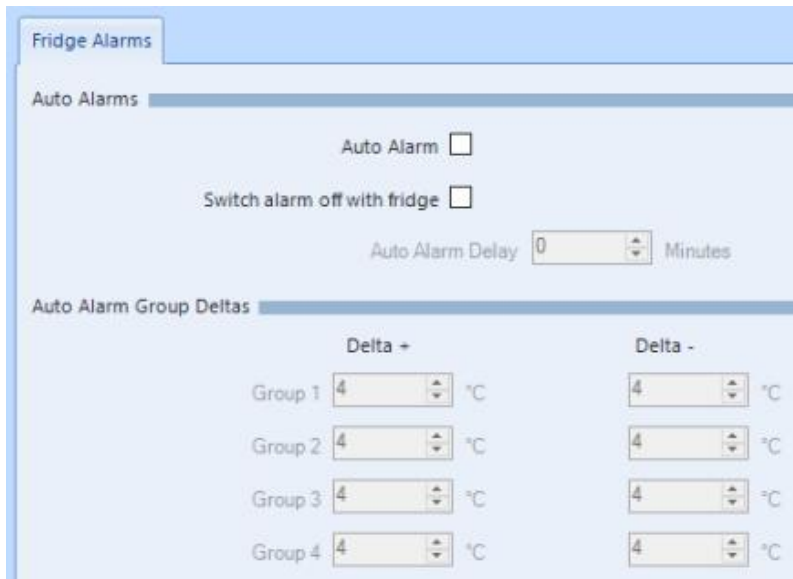

Auto Alarms	
Auto Alarm	Allows you to enable or disable the linking of a compartment to an alarm group and setting the thresholds based on the deltas set in the Auto Alarm Group Deltas section based on the status of the connected fridge.
Switch alarm off with fridge	Allows you to unlink the alarm groups from the compartments in case the fridge turns OFF.
Auto Alarm Delay	Allows you to set a delay between the fridge turning OFF and the unlinking of the alarm groups from the compartments. CAUTION: When using this feature, set the delay to at least 1 minute. Setting the value to 0 has a different behavior depending on the connected fridge model and can lead to unexpected behavior.

Auto Alarm Group Deltas	
Delta +	The upper tolerance from the compartment set point. For example, if the set point is 8°C and the Delta + is 6°C, the upper threshold becomes 14°C. The Delta + can be set to a value between 1°C and 9°C.
Delta -	The lower tolerance from the compartment setpoint. For example, if the setpoint is 8°C and the Delta - is 6°C, the upper threshold becomes 2°C. The Delta - can be set to a value between 1°C and 9°C.
Group x	The delta setting for compartment x.

2.2.1.9 GPS

The GPS menu allows you to configure when to write position and mileage records.

CAUTION: In configurations with an EBS system connected, GPS mileage is not used. In these systems, the platform only uses the EBS reported mileage. If the EBS system is disconnected, the last known mileage from this system is used.

Note The Mileage recorded is calculated based on the distance between successive GPS coordinates on a high frequency. Note that the recorded Mileage value may differ from your vehicle's odometer value.

Position Logging

Loginterval (Time) Minutes (Off)

Loginterval (Distance) Kilometers (Off)

Store position on Temperature

Start/Stop

Stop Detection delay Minutes

Start/stop detection distance Meters

Mileage

Distance record interval (Time) Minutes (Off)

Distance record interval (Distance) Kilometers

Store mileage on stop event

Position Logging	
Loginterval (Time):	Allows you to set a time interval for logging the current position. 0 = disables logging on time interval.
Loginterval (Distance):	Allows you to set a distance interval for logging the current position. Setting this to 0 disables logging on distance interval.
Store position on Temperature:	Allows you to enable / disable the logging of the current position whenever a temperature measurement is stored

Start/Stop	
Stop Detection delay:	Allows you to specify the time period after which the RT 8000 is deemed to have stopped moving.
Start/stop detection distance:	Allows you to set the distance which the RT 8000 may move before detecting whether the RT 8000 is moving.

Mileage	
Distance record interval (Time):	Allows you to set a time interval for logging the current driven mileage. 0 = disables logging on time interval.
Distance record interval (Distance):	Allows you to set a distance interval for logging the current driven mileage. 0 = disables logging on distance interval.
Store mileage on stop event:	Allows you to enable / disable the writing of the current driven mileage after the RT 8000 has detected that it stopped moving.

2.2.1.10 Communication

The Communication menu allows you to set the functions of the RT 8000 communication ports and set the APN and UCP settings for connecting to ColdChainView.

CAUTION: All settings in this menu are always available and are not matched against the variant of the connected RT 8000. When changing the configuration in this menu, always perform an installation qualification to verify the expected behavior according to the selected configuration.



From the Protocols tab, you can set the communication protocol to use on the external communication port. Use the table below to determine which option relates to the connector on the harness cable.

COM1 Function:	Harness ST101400-001: COM1 - Recorder Harness ST101569-001: Rx / Tx / Ground Harness ST101630-001: Recorder Rx / Recorder Tx
COM2 Function:	Harness ST101400-001: Unused Harness ST101569-001 and Harness ST101630-001: Unused
COM3 Function:	Harness ST101400-001: COM3 – Reefer Harness ST101569-001: Unused Harness ST101630-001: Reefer Rx / Reefer Tx
CAN0 Function:	Harness ST101400-001: CAN1 / COM2 Harness ST101569-001 and Harness ST101630-001: Unused
CAN1 Function:	Harness ST101400-001: CAN3 Harness ST101569-001 and Harness ST101630-001: Unused
CAN2 Function:	Harness ST101400-001: Unused Harness ST101569-001 and Harness ST101630-001: Unused

SIM Pincode:	<p>Note This configuration is only applicable when using an external SIM card.</p> <p>Allows you to enter the pincode to unlock the SIM card.</p>
APN Server:	<p>Note This configuration is only applicable when using an external SIM card.</p> <p>Allows you to select predefined operator settings for connecting to a GSM network.</p> <p>CAUTION: Make sure you select the APN settings corresponding to the SIM card in the RT 8000, or the RT 8000 may not be able to get a network connection.</p> <p>CAUTION: If your operator is not listed in the APN Server menu, manually add the:</p> <ul style="list-style-type: none"> * APN Server Address * APN Username * APN Password <p>obtained from the SIM card distributor and then verify that the RT 8000 connects to the network.</p>
UCP Server:	<p>Allows you to select to which ColdChainView server the RT 8000 should connect to.</p> <p>Changing the server automatically uses the correct UCP Server Address and Port.</p> <p>CAUTION: DO NOT manually enter a UCP Server Address and Port unless explicitly instructed. Incorrect settings can result in data being sent to the wrong server.</p>
SIM Source	<p>Allows you to select which SIM card to use to connect to a GSM network.</p> <ul style="list-style-type: none"> * Embedded SIM: Uses the embedded SIM card on the RT 8000. * External SIM: Uses the SIM card installed in the SIM slot of the RT 8000.

2.2.1.11 Fuel

The Fuel menu allows you to set fuel level warnings and log intervals for the RT 8000.

Log interval:	Allows you to set the time interval for recording the fuel level. Setting this to 0 disables this functionality.
Log step interval:	Allows you to set the percentage for recording the fuel level. Setting this to 0 disables this functionality.
Low fuel level warning at:	Allows you to set a threshold of remaining fuel in the tank before activating an alarm. Setting this to 0 disables this functionality.

2.2.1.12 Battery

The Battery menu allows you to enable the logging of battery related information and set thresholds for a low battery alarm.



The RT 8000 internal power manager measures and records the battery voltage.

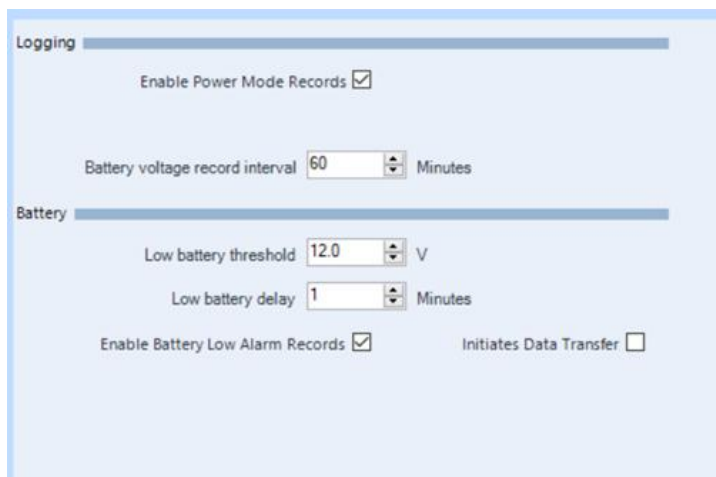

Position	
Enable Power Mode Records:	Allows the writing of battery voltage records, which contain information about the measured (internal) battery voltage and external power supply.
Battery voltage record interval:	Allows you to set an interval to log the current battery voltage. CAUTION: Setting this to 0 disables this functionality.

Battery	
Low battery threshold:	Allows you to set the lower limit for the voltage before the RT 8000 registers it as too low.
Low battery delay:	Allows you to set the time limit before the activation of an alarm when the threshold is exceeded. CAUTION: Setting this to 0 causes the RT 8000 to immediately activate the alarm when it detects low power.
Enable Battery Low Alarm Records	Determines whether to write the low battery alarm record to RT 8000 memory.
Initiates Data Transfer	Determines whether the low voltage alarm record immediately transfers to the server after it is written (option selected) or if the record is transferred with the next periodic data transfer (option not selected).

2.2.1.13 Wireless Sensors

The Wireless Sensors menu allows you to configure up to eight wireless temperature sensors or wireless door sensors to the RT 8000.

CAUTION: After configuring a serial number, assign it to an Analog Sensor/Virtual Temperature Channel (for Wireless Temperature Sensors) or to a Digital Sensors channel (for Wireless Door Sensors) in the respective Configuration menu.

The screenshot shows a configuration window with a title bar. On the right side, there is a dropdown menu currently set to "Temperature Sensor (TS310)". On the left side, there are eight rows, each labeled "Channel X Serial" (where X is 1 through 8). Each row has a corresponding text input field. The first input field contains the serial number "EWBC822070046".

Channel X Serial:	Allows you to add the serial number of a wireless temperature sensor or wireless door contact. DeviceManager software automatically detects the type of sensor based on the serial number and display this after the input field.
--------------------------	---

2.2.1.14 Door Locks

The Door Locks menu allows you to configure settings for door lock related communication.

Note These settings are only used in combination with door lock controllers (connected over either COM or CAN communication) that are approved by ORBCOMM. Please contact your retailer for more information.

The screenshot shows a configuration window with two main elements. At the top, there is a text input field labeled "Doorlock pincode". Below it, there is a dropdown menu labeled "TransSafety Arm/Disarm Mode" which is currently set to "Normal".

Doorlock pincode:	Allows you to set the pincode used for (un)locking and (dis)arming the doorlock.
TransSafety Arm/Disarm Mode:	Allows you to set the locking and arming behavior when using a TransSafety Door Lock Controller. CAUTION: For specifications on the behavior of each mode, please Contact Support.

2.2.1.15 EBS

The EBS menu allows you to configure the information, from a connected EBS unit, that you want the RT 8000 to store.

Note To use this feature, ensure that a suitable EBS unit is connected to the RT 8000 and the appropriate protocol is configured in the Communication menu.

Records Enabled

ABS event <input type="checkbox"/>	Amber warning <input type="checkbox"/>
Retarder event <input type="checkbox"/>	Roll over prevention event <input checked="" type="checkbox"/>
VDC event <input type="checkbox"/>	Yaw Control event <input checked="" type="checkbox"/>
Stoplight event <input type="checkbox"/>	Service brake event <input type="checkbox"/>
Electric status event <input type="checkbox"/>	Pneumatic status event <input type="checkbox"/>

Periodic record interval Hours

Load change step interval Kg

Low tyre pressure threshold kPa

ABS event	Allows storing an additional record when an ABS event occurs
Retarder event	Allows storing an additional record when a Retarder event occurs
VDC event	Allows storing an additional record when a VDC event occurs
Stoplight event	Allows storing an additional record when a Stoplight event occurs
Electric status event	Allows storing an additional record when an Electric status event occurs
Amber warning	Allows storing an additional record when an Amber warning event occurs
Roll over prevention event	Allows storing an additional record when a Roll over prevention event occurs
Yaw Control event	Allows storing an additional record when a Yaw Control event occurs
Service brake event	Allows storing an additional record when a Service brake event occurs
Pneumatic status event	Allows storing an additional record when a Pneumatic status event occurs
Periodic record interval	Allows you to set a time interval (in hours) for logging all available EBS data from the EBS system. 0 = disables logging on time interval
Load change step interval	Allows you to set a weight interval (in kilograms) for logging the load data from the EBS system. Only when the delta between the last stored value and the new received value exceeds the value of this setting, is a record written. 0 = disables logging on weight interval.
Low tyre pressure threshold	Allows you to set a pressure threshold (in kilopascal) for detecting low tyre pressure from the EBS system. 0 = disables detection of low tyre pressure

2.3 Configure the Peripherals

This section describes the parameters and functions you can set from the DeviceManager Configuration menu when adding peripherals to the RT 8000. Refer to section 2.2 to configure the RT 8000 or view sub-menus not shown in this section.

2.3.1 Perform Basic Network Setup Configuration

The DeviceManager **Configuration** menu (Configuration) includes the sub-menu items in the list below. To complete a basic networked setup configuration, check all underlined items before continuing with the Installation Qualification chapter.

- [...]
- [Analog Sensors](#)
- [Virtual Temperatures](#)
- [Digital Sensors](#)
- [...]
- [Communication](#)
- [...]

2.3.1.1 Analog Sensors / Virtual Temperatures Settings

To map the networked temperature sensor:

1. From the **Configuration** menu, select either **Analog Sensors** or **Virtual Temperatures** (sensors) depending on which applies to your setup.
2. Select the tab for the sensor you want to map.
3. Set **Sensor type** to **External Sensor**.
4. Use the **External sensor type** drop-down menu to select the appropriate option, where Input x is the sensor channel on the connected temperature sensor (for example, an MX2), and COMx is the communication port where you connected the RT 8000.

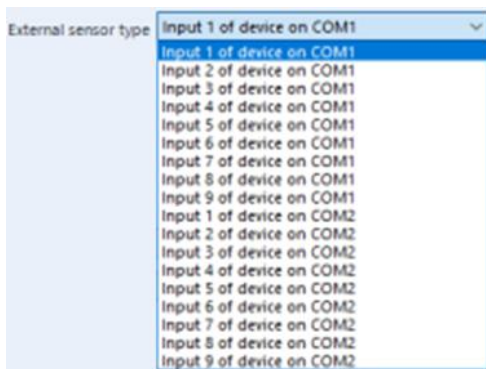

2.3.1.2 Digital Sensors Settings

To map the networked digital sensors:

1. From the **Configuration** menu, select **Digital Sensors**.
2. Select the tab for the digital sensor you want to map.
3. Set **Input level** to **External Sensor**.
4. Use the **External sensor** drop-down menu to select the appropriate option, where Input x is the sensor channel on the connected temperature sensor (for example, an MX2), and COMx is the communication port where you

connected the RT 8000.

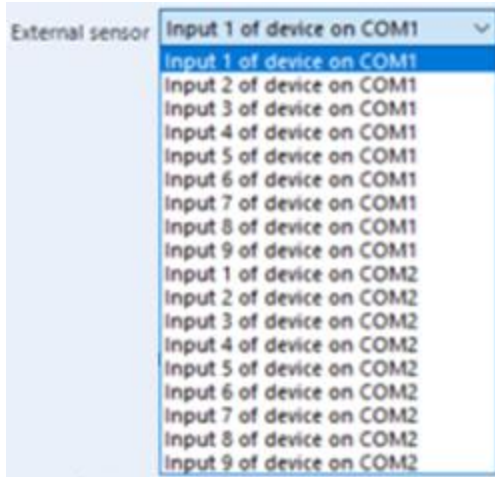

2.3.1.3 Communication Settings

From this sub-menu you can edit RT 8000 general information and settings.

1. From the **Configuration** menu, select **Communication**, and then on the **Protocols** tab, set the protocol for the COM port where you connected the networked device as per the following table.

External Device	COM Function
Euroscan MX1 / MX2 / X2-6 / X3	UCP Protocol
Carrier Datacold 600	UCP Protocol
Carrier eSolutions Box	UCP Protocol
Euroscan X2-4	Remote DC500/X1 Protocol
Carrier Datacold 500	Remote DC500/X1 Protocol
Transcan / Transcan-2	Transcan Protocol
Transcan Advance	Transcan Advance Protocol
Thermo King TouchPrint	TouchPrint Protocol

In the example that follows, a Euroscan X3 is connected to COM1 on the RT 8000.

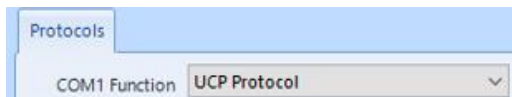

Note By default, COM1, COM2, and COM3 are set to UCP Protocol for an RT 8000.

2. Select the **External Protocol** tab, for the temperature sensor's networked COM port, and set the **Polling Mode** to **Polling**. As per the earlier example, the Euroscan X3 connected to COM1 has the associated COM 1 Protocol

Mode set to Polling.

The screenshot shows a configuration window with three settings for the COM port:

- COM % Protocol Mode: Receive (dropdown menu)
- COM % Polling Mode: Polling (dropdown menu)
- COM % Polling interval: 20 (spin box) Seconds

2.4 Reset the RT 8000 Configuration

You can reset the RT 8000 configuration either using DeviceManager or AccountManager (only when connected to a ColdChainView server).

2.4.1 Configuration Reset Using DeviceManager (Local)

To reset the RT 8000 using DeviceManager:

1. Connect the RT 8000 to a computer either with a serial (RS-232) or Bluetooth connection. For instructions, refer to section 2.1.
2. In DeviceManager, navigate to the **Install & Maintenance** menu, and click **Parameter Reset**. The configuration is reset to the factory default, except for:
 - I/O settings
 - Communication Protocol settings (only COM/CAN Port protocol selection is reset)
 - Calibration settings
 - Device specific settings (hardware version, serial number and firmware version)

2.4.2 Configuration Reset Using Account Manager (OTA)

To reset the RT 8000 using AccountManager:

1. In AccountManager, select the RT 8000 in the respective customer account.
2. Navigate to the **Commands** menu, and then send the **Parameter Reset** command. The device resets the configuration to the factory default, except for:
 - I/O settings
 - All Communication settings (COM/CAN Port protocol selection and APN/TCP settings)
 - Calibration settings
 - Device specific settings (hardware version, serial number and firmware version)

3 INSTALLATION QUALIFICATION



Before leaving the installation location, check all applicable tests below, especially sections 3.1 and 3.2.

3.1 RT 8000

Test	
Is the RT 8000 running the most recent firmware? <i>Check the Active Device Status window.</i>	
A1	In the General information box, the current (recorder) firmware and Modem firmware are shown. The device is up to date if the message "(upgrade available)" is not displayed. 
A2	If the message "(upgrade available)" is displayed behind the firmware version, then update the device according to the instructions in document [E0003] .

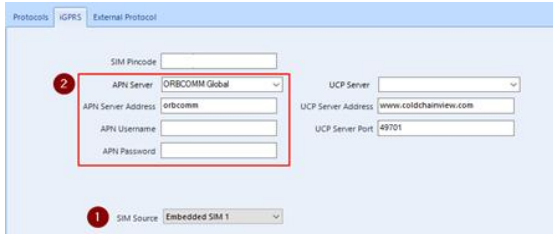



3.2 Communication

Test	
Does the RT 8000 indicate it is connected to the server? <i>Check the Online Info section of the Device Information screen</i>	
A1	Ensure that an activated SIM card is inserted into the RT 8000. Note ▶ This is only applicable when using an external SIM card.
A2	Make sure that the RT 8000 is either: - configured to use the internal embedded SIM card (1) - correctly configured for the inserted (external) SIM card (1) & (2). Check this in Configuration > Communication > iGPRS tab. 
A3	Make sure that the RT 8000 is in a location where it has the possibility to connect to a telecom provider.

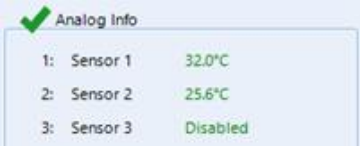
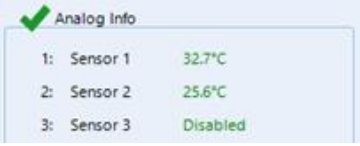
A4	<p>In the Online Info box of the Device Information window, the current status of the modem is shown. If there are green check marks in the SIM status, Registered on network, and Connected to server lines, then the device is properly connected to the server.</p> 
<p>Is the current GPS location of the RT 8000 available? <i>Check the Position Info section of the Device Information screen.</i></p>	
B1	<p>Make sure that the RT 8000 is in a location where it has clear view of the sky.</p>
B2	<p>In the Device Information window > Position Info box you see the current status of the GPS module. If you see a valid coordinate and the text "OK", then the GPS module is working properly.</p> 



3.3 Sensors

Test	
<p>Are the connected temperature sensors working as expected? <i>Check the Analog Info section of the Device Information screen.</i></p>	
A1	<p>Check the status of the configured temperature sensor on the Device Information screen, and then verify that you see a (temperature) value.</p> 
A2	<p>Expose the sensor to a heat source and check the status on the Device Information screen by clicking refresh. The (temperature) value of the sensor should have increased.</p> 

A3	<p>Expose the sensor to a cold source and check the status on the Device Information screen by clicking refresh. The (temperature) value of the sensor should have decreased. If this test succeeds, the sensor is working properly.</p> 
<p>Are the digital contacts working as expected? <i>Check the Digital Info section of the Device Information screen.</i></p>	
B1	<p>Close the circuit of the digital contact, and then check the status on the Device Information screen. The status should be either Active or Inactive, based on the configuration of the digital contact.</p> 
B2	<p>Open the circuit of the digital contact, and then check the status on the Device Information screen by clicking refresh. Verify that the status changed from Inactive to Active (or vice-versa).</p> 
B3	<p>Close the circuit of the digital contact again, and then check the status on the Device Information screen by clicking refresh. If the status has changed back to the initial status of step B1, the contact is working properly.</p> 

3.4 Peripherals

 The provided installation qualification steps may depend on the RT 8000 firmware version. Ensure that your RT 8000 is running the latest version before performing the steps.

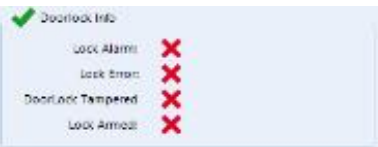
Test	
Does the RT 8000 indicate an active fridge connection? <i>Ensure the fridge is ON, and then check the Device Information screen.</i>	
A1	Ensure that the RT 8000 and the fridge are connected properly, and the fridge is turned ON.
A2	Connect the RT 8000 to DeviceManager and verify that the Fridge information panel is visible to the right of the Analog Info panel. 
A3	Change the setpoint of one of the enabled compartments, and then click refresh on the Device Information screen. If the status in the Fridge Panel has updated to the new setpoint, then the communication is working properly. 
Does the RT 8000 indicate an active doorlock connection? <i>Requires a functional doorlock and can be checked in Doorlock info panel in DeviceManager.</i>	
B1	Ensure that the RT 8000 and the doorlock controller are connected properly, and the doorlock controller is powered.
B2	Connect the RT 8000 to DeviceManager and verify that the Doorlock information panel is visible to the right of the Analog Info panel. 
Does the RT 8000 indicate an active EBS connection? <i>Requires a functional EBS and can be checked in EBS info panel in DeviceManager.</i>	
C1	Ensure that the RT 8000 and the EBS modulator is powered and connected properly.

C2	<p>Connect the RT 8000 to DeviceManager and verify that the EBS information panel is visible to the right of the Analog Info panel.</p>  <p>The screenshot shows a light blue panel titled 'EBS Connection' with a green checkmark icon. Below the title, the following data is displayed:</p> <table border="1"> <tr> <td>Axles</td> <td>3</td> </tr> <tr> <td>Wheels</td> <td>2</td> </tr> <tr> <td>Trailer Load</td> <td>2500 kg</td> </tr> <tr> <td>ODO Meter</td> <td>206881.3 mi</td> </tr> <tr> <td>Tyre Temperature</td> <td>✓</td> </tr> <tr> <td>Tyre Pressure</td> <td>✓✓</td> </tr> <tr> <td>Brake Temperature</td> <td>✓✓</td> </tr> </table>	Axles	3	Wheels	2	Trailer Load	2500 kg	ODO Meter	206881.3 mi	Tyre Temperature	✓	Tyre Pressure	✓✓	Brake Temperature	✓✓
Axles	3														
Wheels	2														
Trailer Load	2500 kg														
ODO Meter	206881.3 mi														
Tyre Temperature	✓														
Tyre Pressure	✓✓														
Brake Temperature	✓✓														
C3	<p>Check that the data displayed corresponds to the data generated by the EBS system.</p>														

4 MAINTENANCE

4.1 Inspection

Perform a visual inspection of the RT 8000 and harness cables. Especially look for cracks in the housing, rust, oxidation, cut or broken cables, and cured rubbers.

4.2 RMA

For any RMA issues, [Contact Support](#).

4.3 RT 8000 Calibration

The RT 8000 has an option to adjust the offset of the A/D converter with correction factors. These correction factors are fixed parameters used in the formula that converts the measured resistance into the corresponding temperature. This procedure is applicable for calibrating individual sensors. Note that the effect on the measured and displayed temperature is not linear.

It is recommended you repeat this procedure on a regular basis (that is, at the annual reference check) as recommended by the EN13486 standard.

CAUTION: Only ORBCOMM certified installers are authorized to execute a calibration procedure.

CAUTION: When executing the calibration procedure, ensure that the appropriate reference equipment is used according to the standards described in the EN13486.

CAUTION: When executing the calibration procedure, ensure that a defined procedure is set up and maintained.

Perform calibration using the DeviceManager software program, which allows an installer to define up to six calibration point values for each configured temperature input of the RT 8000.

In the Calibration menu of DeviceManager, specify the amount of calibration points and the calibration temperature values in ascending order (starting with the lowest temperature).

The screenshot shows the 'Calibration' window in DeviceManager. At the top, it says 'Calibrations changed: 0'. There are seven tabs: 'Calibration Settings', 'Calibration Point 1', 'Calibration Point 2', 'Calibration Point 3', 'Calibration Point 4', 'Calibration Point 5', and 'Calibration Point 6'. The 'Calibration Settings' tab is selected. It contains a dropdown menu for 'Number of calibration points' with the value '0'. Below this are six rows, each representing a calibration point. Each row has a temperature input field (a spinner box) set to '0.0' and a unit selector set to '°C'.

The respective Calibration Point x tabs are available after selecting the number of Calibration Points. For example, when selecting 2 Calibration points, the tabs "Calibration Point 1" and "Calibration Point 2" become available.

The Calibration Point tab displays the calibration values entered on the Settings tab and the uncalibrated Sensor values for each configured temperature sensor.

The screenshot shows the 'Calibration' window with 'Calibrations changed: 2'. The 'Calibration Point 1' tab is active, showing a reference value of -13.0 and a 'Calculate' button. Below is a table of sensor data:

Sensor	Uncalibrated Sensor Value	Deviation
Sensor 1	25.7°C	0.0
Sensor 2	-13.3°C	0.0
Sensor 3	N/A	0.0
Sensor 4	N/A	0.0
Sensor 5	N/A	0.0
Sensor 6	N/A	0.0
Sensor 7	N/A	0.0
Sensor 8	N/A	0.0
Sensor 9	N/A	0.0
Sensor 10	N/A	0.0

In this menu, you can input the actual reference value and click **Calculate** to automatically determine the deviation for all selected sensors, or you can manually input the deviation.

After calibration, you can save the settings to the RT 8000 by clicking  (**apply**). The following information is then stored in the RT 8000:

- The number of calibration points used
- The (reference) value for each calibration point
- The deviation value for each sensor per calibration point
- The Unix timestamp when the calibration was performed.

CAUTION: If one of the sensors does not pass the test or the deviation is too large ($>\pm 2.0^{\circ}\text{C}$), the sensor should be replaced, and the test performed again. If the result is still negative, [Contact Support](#).

4.4 Remove the RT 8000

CAUTION: DO NOT apply any excessive force to remove an RT 8000.

To remove the RT 8000, disconnect the harness cable and antennas from the RT 8000, and then remove the mounting screws on the RT 8000 housing.

4.5 Restart the RT 8000

You can restart the RT 8000 either using DeviceManager (soft reboot) or by the reset pin (hard reboot).

4.5.1 Restart Using DeviceManager

To restart an RT 8000 using DeviceManager:

1. Connect the RT 8000 to a computer via either a serial (RS-232) or Bluetooth connection. Refer to section 2.1 for details.
2. In DeviceManager, navigate to the **Install & Maintenance** menu, and then click **Reboot Device**. The RT 8000 performs a soft reboot, which restarts the application on the device. Power is not interrupted with this action.

4.5.2 Restart Using the Reset Pin

To restart an RT 8000 using the reset pin:

1. Open the SIM card door by unscrewing the two Philips heads screws.



2. Use a small tool (needle, paper clip, or skewer) to press the reset button located next to the SIM card slot. The RT 8000 performs a hard reboot, which power cycles the entire device. Power is interrupted briefly to perform the restart.



5 CERTIFICATION AND COMPLIANCE

E-Mark

EN 12830:2018¹ Class 0.5

CE RED 2014/53/EU

RoHS²

GAMP 5

Ingress Protection

- RT 8000: IP65

EU Declaration of Conformity

Hereby, ORBCOMM Inc. declares that the radio equipment types listed in this document comply with Directive 2014/53/EU.

The full text of the EU declaration of conformity is available from <http://www2.orbcomm.com/eudoc>.

Regulatory Model Number

Regulatory Model Number	Order Part Number	Description
RT8000-1	RT8000-1100	RT 8000 with external BLE capability, integrated cell and GPS antennas, 1 x RS-232, 1 x RS-232/RS-485, 2 x CAN, and 10 x I/O
RT8000-2	RT8000-2100	RT 8000 with external cell/GPS/BLE capability, 1 x RS-232, 1 x RS-232/RS-485, 2 x CAN, and 10 x I/O

¹Certification is valid when using wired sensors included in the ORBCOMM Temperature Sensor [datasheet](#) or wireless [TS 310](#) sensors connected via the RT 8000.

²European Union's (EU) Directive 2015/863 "Restriction of Hazardous Substances" (RoHS) in Electronic and Electrical Equipment.

APPENDIX A ORDER PART NUMBERS

RT 8000	Description
RT8000-1100	RT 8000 with integrated cell / GPS antenna, 1 x RS-232, 1 x RS-232/RS-485, 2 x CAN, 1 x 1-Wire, and 10 x I/O. For peripherals (cable harness, external BLE antenna, and sensors), see sales kits and additional parts and accessories.
SM202781-001	Sales kit: RT8000-1100 with a cable harness.
SM202781-002	Sales kit: RT8000-1100 with a cable harness and an external BLE antenna.
SM202781-003	Sales kit: RT8000-1100 with a cable harness and two wired sensors (6 m and 22 m).
SM202781-004	Sales kit: RT8000-1100 with a cable harness, an external BLE antenna, and two TS 310 wireless sensors.
RT8000-2100	RT 8000 with 1 x RS-232, 1 x RS-232/RS-485, 2 x CAN, 1 x 1-Wire, and 10 x I/O. For peripherals (cable harness, external cell / GPS antenna, external BLE antenna, and sensors), see sales kits and additional parts and accessories.
SM202783-001	Sales kit: RT8000-2100 with a cable harness and an external cell / GPS antenna.
SM202783-002	Sales kit: RT8000-2100 with a cable harness, an external cell / GPS antenna, and an external BLE antenna.
SM202783-003	Sales kit: RT8000-2100 with a cable harness, an external cell / GPS antenna, and two wired sensors (6 m and 22 m).
SM202783-004	Sales kit: RT8000-2100 with a cable harness, an external cell / GPS antenna, an external BLE antenna, and two TS 310 wireless sensors.

Additional Parts and Accessories	Description
Harness and Cables	
ST101400-001	RT 8000 breakout cable harness, 3 m (10 ft.)
ST101569-001	RT 8000 peripheral harness, 1.25 m
004.000.0070	RT 8000/MX2, UCP 3-wire cable
004.001.0026	RT 8000/MX2 service cable (connect over RT 8000 connector)
ST101630-001	RT 8000 universal harness, IP67 (mated), 1.5 m (5 ft.)
008.010.0041	Serial cable RS-232 set
Antennas	
ST101087-004	External cell / GPS antenna (LTE / GNSS), black enclosure, FAKRA (bordeaux / blue) connector, 5 m, side connector
ST101496-004	BLE antenna, IP67, adhesive mount, FAKRA (beige), 2.4 GHz, 4.5 m
ST101496-003	BLE antenna, non-IP67, adhesive mount, FAKRA (beige), 2.4 GHz, 4.5 m
Connectors	
CON100367	FAKRA Z-code waterproof male connector plug / cap
ST101096	ST 9100 field installable IP67, 24-pin connector
Wireless Sensors	
Temperature Sensors	Refer to section 1.6.2
Door Switches	Refer to section 1.6.3
Wireless Sensors	Refer to section 1.6.4
002.000.0020	Temperature sensor bracket cable guard

Additional Parts and Accessories	Description
Other	
009.002.0070	Bluetooth dongle

APPENDIX B TECHNICAL SPECIFICATIONS

Power:

- Supply voltage: 10 to 32 VDC

Temperature Range:

- RT 8000 Operation temperature range: -40°C / +85°C (-40°F / 185°F)
 - Back-up battery range: -20°C to +75°C (-4°F to +167°F)

Memory Size

- 256 MB, minimum 1 year with 12 sensors and reefer communication on a 10 min logging interval

Interfaces

- 10 x GPIO connections for external temperature sensors or digital contacts ¹
- 1 x RS-232 serial port
- 1 x RS-232/RS-485 serial port
- 1 x 1-Wire
- 2 x CAN buses
- 1 x Bluetooth Low Energy
- 1 x 3-axis accelerometer for shock detection up to 8G
- 1 x Internal backup battery pack

Communications (modem / online functionality):

- CAT 1 4G LTE (2G/3G support) GSM
- EMEA
 - 2G (GSM/EDGE) B3/B8
 - 3G (WCDMA) B1/B8
 - 4G (LTE FDD) B1/B3/B7/B8/B20/B28
- GNSS
- Wireless connectivity: Bluetooth version 5.3

Environmental

- Shock: MIL-STD-810G (Sec 516.6)
- Vibration: SAE J1455 (Sec 4.9.4.2 fig 6-8); MIL-STD-810G

Immunity





- EN 61000-6-2 and EN 61000-6-3





Mechanical:

- Dimensions: 181 mm x 113 mm x 48 mm (7.1" x 4.4" x 1.9") includes mounting feet
- Weight:
 - RT 8000-1100 - 0.489 kg (1.08 lb) excludes the wiring harness. Wiring harness adds 1.33 kg (2.93 lb).
 - RT 8000-2100 - 0.450 kg (1.00 lb) excludes the wiring harness. Wiring harness adds 1.33 kg (2.93 lb).

¹Depends on the RT 8000 variant.

APPENDIX C RT 8000 LED DESCRIPTION

Icon	Color	Function	Description
	BLUE	BLE	Indicates BLE communication status
	GREEN	Cellular	Indicates cellular communications status
	YELLOW	GPS	Indicates GPS communication status
	RED	Power	Indicates external power supply and internal battery status

	LED Repeating Pattern				
	ON	ON for 2 seconds and then OFF	Blinking	OFF for 2 seconds and then ON	OFF
	Connected to DeviceManager software via Bluetooth	BLE available, waiting for connection	-	Connected to wireless sensors	BLE not available
	Not Used	Connected to network / server	Fast Blinking: Communicating with the server / data transfer in progress	Searching for network / server	No connection
	Searching for satellites (0 found)	Searching for satellites (1 found)	Fast Blinking: Searching for satellites (4 found)	3D fix obtained	GPS not available
	RT 8000 running on external power supply	Running on internal battery pack; battery pack charge between 68% and 100%	Slow Blinking: Running on internal battery pack; battery pack charge between 33% and 67%	Running on internal battery pack; battery pack charge between 0% and 32%	No power supply

APPENDIX D TEMPERATURE REGISTRATION AND ALARMS

D.1 Temperature Registration

Sampling and Registration

The RT 8000 constantly measures temperature data from the connected temperature sensors. This measurement data is used to calculate 20 equally spaced running average values over a specified period, set in the configuration of the RT 8000 (logging interval; default: 10 minutes).

This means that for a logging interval of 10 minutes, a new running average is calculated every 30 seconds using a sample value. The sample that is used is the current actual temperature value of the temperature sensor, which is measured by the RT 8000.

When the logging interval is reached, the running average value calculated at that time is permanently stored in the memory of the RT 8000 as a temperature record with a resolution of 0.1°C. The value stored in this temperature record is the value that is sent to ColdChainView (in cases where the RT 8000 reports to a CCV server).

Example:

- Record Interval = 10 minutes

Time	T.Actual	R.Average	Event
10:00:00	5	5,00	Stored temperature value: 5.0°C
10:00:30	6	5,56	-
10:01:00	7	5,74	-
10:01:30	8	6,02	-
10:02:00	9	6,40	-
10:02:30	10	6,85	-
10:03:00	11	7,37	-
10:03:30	12	7,95	-
10:04:00	14	8,70	-
10:04:30	15	9,49	-
10:05:00	16	10,30	-
10:05:30	17	11,14	-
10:06:00	18	12,00	-
10:06:30	18	12,75	-
10:07:00	19	13,53	-
10:07:30	17	13,96	-
10:08:00	16	14,22	-
10:08:30	16	14,44	-
10:09:00	16	14,64	-
10:09:30	15	14,68	-
10:10:00	15	14,72	Stored temperature value: 14.7°C
10:10:30	13	14,93	-

Time	T.Actual	R.Average	Event
10:11:00	12	14,56	-
10:11:30	11	14,11	-
10:12:00	10	13,60	-
10:12:30	8	12,90	-
10:13:00	7	12,16	-
10:13:30	6	11,39	-
10:14:00	5	10,59	-
10:14:30	5	9,89	-
10:15:00	5	9,28	-
10:15:30	5	8,75	-
10:16:00	5	8,28	-
10:16:30	6	7,99	-
10:17:00	6	7,74	-
10:17:30	7	7,65	-
10:18:00	7	7,57	-
10:18:30	8	7,62	-
10:19:00	9	7,80	-
10:19:30	10	8,07	-
10:20:00	11	8,44	Stored temperature value: 8.4°C
10:20:30	12	9,29	-
10:21:00	12	9,63	-
10:21:30	12	9,92	-
10:22:00	12	10,18	-
10:22:30	11	10,28	-
10:23:00	10	10,25	-
10:23:30	10	10,22	-
10:24:00	10	10,19	-
10:24:30	10	10,17	-
10:25:00	10	10,15	-
10:25:30	9	10,00	-
10:26:00	9	9,88	-
10:26:30	9	9,77	-
10:27:00	8	9,55	-
10:27:30	8	9,35	-
10:28:00	8	9,18	-
10:28:30	7	8,91	-
10:29:00	6	8,55	-
10:29:30	5	8,10	-
10:30:00	5	7,72	Stored temperature value: 7.7°C

The temperatures listed in column "T.Actual" are the actual temperatures measured by the RT 8000. This is the sample value taken to calculate the new (running) average value.

The temperatures in column "R.Average" indicate the calculated running averages that are stored temporarily in the memory of the RT 8000.

The R.Average calculated at the moment when the record interval is reached, is permanently stored in the memory of the RT 8000 as a temperature record with a resolution of 0.1°C. This is the value sent to ColdChainView (in cases where the device reports to a CCV server).

D.2 Alarms

Requirements

To set up an alarm for a temperature sensor, enable the following settings in the configuration of the RT 8000:

- In the Analog Sensors menu:
 - The Analog Sensor is enabled, (**Temperature X On** is selected).
 - The Analog Sensor is assigned to a single compartment for alarm monitoring, (**Alarm on compartment X** is selected).
- In the Compartments menu:
 - The Compartment where the sensor is assigned is enabled, (**Compartment X On** is selected).
 - An Alarm Group is assigned to the Compartment (**Alarmgroup** is not set to No Alarmgroup).
- In the Alarms menu:
 - The Alarm Group where the compartment is linked is enabled, (**Alarm X On** is selected).
 - Initial Delay, Upper Alarm Delay and Lower Alarm Delay are set to a value greater than 0.
 - Upper Threshold and Lower Threshold are set to the maximum and minimum allowed temperatures respectively.

Detection Mechanism

When a temperature sensor is assigned to a compartment and an alarm group is activated for the compartment, then the RT 8000 continuously monitors if the temperature is outside of the bounds created by the alarm group thresholds for a specified period (defined by either the upper or lower alarm delay, depending on the exceeded threshold).

This monitoring starts from the moment that the initial delay has passed and ends when the linking of the compartment and alarm group has ended.

The initial delay pauses the complete alarm check for the given time from the moment the alarm group is linked to the compartment. This delay can be used to allow a fridge to cool the load to the correct temperature just after cargo is loaded and can prevent unnecessary alarms within the cooling period.

If a temperature sensor is outside of the bounds specified by the alarm group thresholds over the specified time in the upper or lower delay, then the temperature recorder registers an alarm situation.

The RT 8000 can check for alarms based on either the "Actual temperature" or the "Running Average Temperature". This is defined per-sensor in the configuration of the RT 8000 (parameter **Alarm on Average** (default) / **Actual**).

Temperature 1 On

Sensor function: Return Air

Sensor name: Sensor 1

Sensor type: Temp. Standard

External sensor type: Input 1 of device on COM1

Print on compartment 1 Alarm on compartment 1

Print on compartment 2 Alarm on compartment 2

Print on compartment 3 Alarm on compartment 3

Print on compartment 4 Alarm on compartment 4

Logging method: Average

Alarm on: Average

Examples:

Example 1 – Alarm on (Running) Average Temperature Values

- Initial delay = 0 minutes
- Lower delay = 3 minutes
- Upper delay = 3 minutes
- Record Interval = 10 minutes
- Lower limit = 0°C
- Upper limit = 10°C
- Sensor Alarm on = Average

Time	T.Actual	R.Average	Alarm	Event
10:00:00	5	5.00	-	Alarm group activated. No initial delay configured.
10:00:30	6	5,56	-	-
10:01:00	7	5,74	-	-
10:01:30	8	6,02	-	-
10:02:00	9	6,40	-	-
10:02:30	10	6,85	-	T.Actual above upper limit threshold.
10:03:00	11	7,37	-	-
10:03:30	12	7,95	-	-
10:04:00	14	8,70	-	-
10:04:30	15	9,49	-	-
10:05:00	16	10,30	-	R.Average above upper limit threshold; Upper delay timer starts running.
10:05:30	17	11,14	-	-
10:06:00	18	12,00	-	-
10:06:30	18	12,75	-	-
10:07:00	19	13,53	-	-

Time	T.Actual	R.Average	Alarm	Event
10:07:30	17	13,96	-	-
10:08:00	16	14,22	X	Upper delay timer reached, activating alarm.
10:08:30	16	14,44	X	-
10:09:00	16	14,64	X	-
10:09:30	15	14,68	X	-
10:10:00	15	14,72	X	Periodic stored temperature with value: 14.7°C
10:10:30	13	14,93	X	-
10:11:00	12	14,56	X	-
10:11:30	11	14,11	X	-
10:12:00	10	13,60	X	-
10:12:30	8	12,90	X	T.Actual within thresholds.
10:13:00	7	12,16	X	-
10:13:30	6	11,39	X	-
10:14:00	5	10,59	X	-
10:14:30	5	9,89	-	R.Average within thresholds, disabling alarm.
10:15:00	5	9,28	-	-

Example 2 – Alarm on Actual Temperature Values

- Initial delay = 0 minutes
- Lower delay = 2 minutes
- Upper delay = 2 minutes
- Record Interval = 10 minutes
- Lower limit = 0°C
- Upper limit = 10°C
- Sensor Alarm on = Actual

Time	T.Actual	R.Average	Alarm	Event
10:00:00	5	5,00	-	Alarm group activated. No initial delay configured.
10:00:30	6	5,56	-	-
10:01:00	7	5,74	-	-
10:01:30	8	6,02	-	-
10:02:00	9	6,40	-	-
10:02:30	10	6,85	-	T.Actual above upper limit threshold, Upper delay timer starts running.
10:03:00	11	7,37	-	-
10:03:30	12	7,95	-	-
10:04:00	14	8,70	-	-
10:04:30	15	9,49	X	Upper delay timer reached, activating alarm. Note: The average temperature value is still within the alarm bounds.

Time	T.Actual	R.Average	Alarm	Event
10:05:00	16	10,30	X	-
10:05:30	17	11,14	X	-
10:06:00	18	12,00	X	-
10:06:30	18	12,75	X	-
10:07:00	19	13,53	X	-
10:07:30	17	13,96	X	-
10:08:00	16	14,22	X	-
10:08:30	16	14,44	X	-
10:09:00	16	14,64	X	-
10:09:30	15	14,68	X	-
10:10:00	15	14,72	X	Periodic stored temperature with value: 14.7°C
10:10:30	13	14,93	X	-
10:11:00	12	14,56	X	-
10:11:30	11	14,11	X	-
10:12:00	10	13,60	X	-
10:12:30	8	12,90	-	T.Actual within thresholds, disabling alarm. Note: The average temperature value is still out of the alarm bounds.
10:13:00	7	12,16	-	-
10:13:30	6	11,39	-	-
10:14:00	5	10,59	-	-
10:14:30	5	9,89	-	R.Average within thresholds
10:15:00	5	9,28	-	-

Example 3 – Preventing Alarms Using Initial Delay

- Initial delay = 4 minutes
- Lower delay = 3 minutes
- Upper delay = 3 minutes
- Record Interval = 10 minutes
- Lower limit = 0°C
- Upper limit = 10°C
- Sensor Alarm ON = Average

Time	T.Actual	R.Average	Alarm	Event
10:00:00	20	20,00	-	Alarm group activated, initial delay timer starts running, and Fridge starts cooling.
10:00:30	16	19,94	-	-
10:01:00	11	18,82	-	-
10:01:30	6	17,22	-	-

Time	T.Actual	R.Average	Alarm	Event
10:02:00	5	15,69	-	Fridge reaches required T.Actual value
10:02:30	5	14,35	-	-
10:03:00	5	13,18	-	Note: If no initial delay was used, then an alarm would be activated.
10:03:30	5	12,16	-	-
10:04:00	5	11,27	-	Initial delay timer reached. R.Average (still) above upper limit threshold, upper delay timer starts running.
10:04:30	5	10,48	-	-
10:05:00	5	9,80	-	R.Average within thresholds. Stop and reset upper delay timer.
10:05:30	5	9,20	-	-
10:06:00	5	8,67	-	-
10:06:30	5	8,21	-	-
10:07:00	5	7,81	-	-
10:07:30	5	7,46	-	-
10:08:00	5	7,15	-	-
10:08:30	5	6,88	-	-
10:09:00	5	6,65	-	-
10:09:30	5	6,44	-	-
10:10:00	5	6,26	-	Periodic stored temperature with value: 6.3°C
10:10:30	5	6,58	-	-
10:11:00	5	6,38	-	-
10:11:30	5	6,21	-	-
10:12:00	5	6,06	-	-
10:12:30	5	5,92	-	-
10:13:00	5	5,81	-	-
10:13:30	6	5,83	-	-
10:14:00	5	5,73	-	-
10:14:30	5	5,64	-	-
10:15:00	5	5,56	-	-

APPENDIX E INCLEMENT WEATHER INSTALLATION GUIDELINES

The primary means of securing the ORBCOMM device to an asset is double-sided tape. Proper tape application requires that the tape is kept warm (room temperature), and the asset surface is both clean and dry.

Mandatory Guidelines for Installation in Wet Weather

The installation surface on the asset must be completely clean and dry for the tape to bond. If it is raining or snowing hard enough that the surface cannot be kept dry, do **NOT** proceed with the installation.

Mandatory Guidelines for Installation in Cold Weather

Below 15°C (60°F) the tape starts becoming firm which makes it more difficult to bond to the asset.

If the guidelines below are followed correctly, the ORBCOMM device can be installed at temperatures down to -20°C (-5°F).

CAUTION: For tether installations, the install temperature must be above 15°C (60°F).

- At or below freezing temperatures (0°C or 32°F), both the ORBCOMM device and the tape primer must be kept at room temperature, for example, inside an idling vehicle or a warm building.
- Keep the primer warm (room temperature) until ready to apply. The primer will not dry quickly at cold temperatures however, in this situation the tape should be applied when the primer is still wet, as it improves initial bond.
- Keep the ORBCOMM device warm (room temperature) until it is time to mount it to the asset.
- Press firmly on the entire top surface of the ORBCOMM device (7 kg (15 pounds) for 60 seconds) to bond the tape to the asset.
- Failing to follow these guidelines will compromise the installation.



APPENDIX F CABLE HARNESS WIRING CONNECTIONS

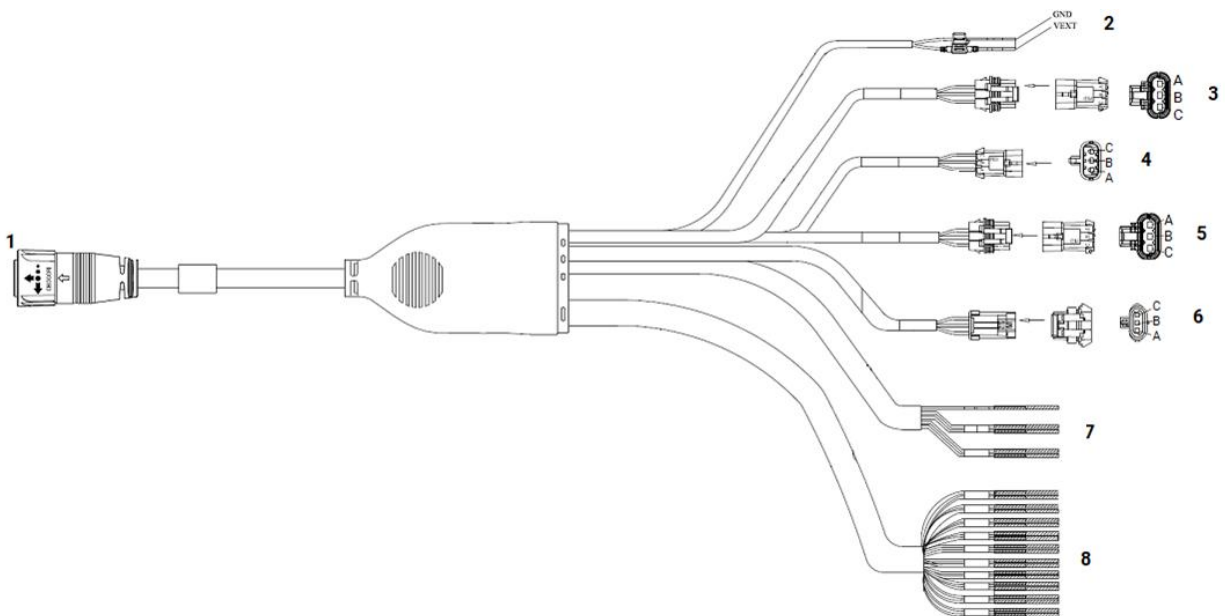
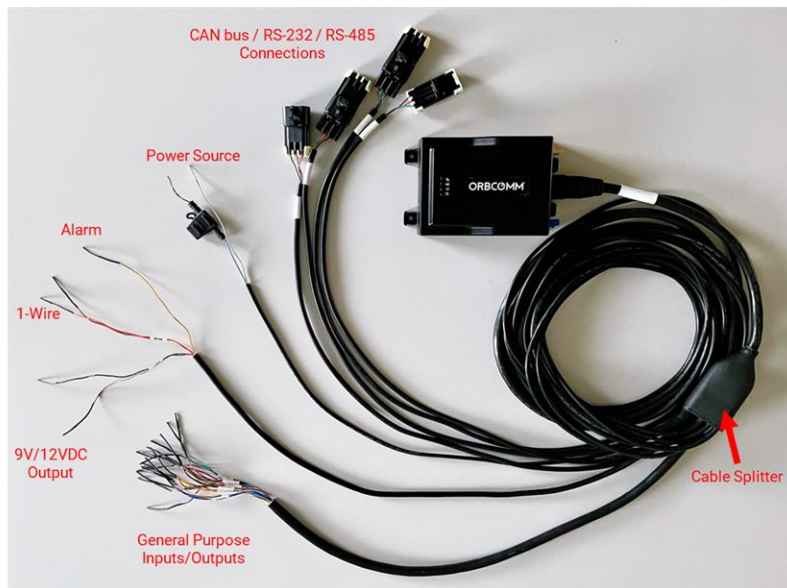

CAUTION: You must incorporate cable management and connector strain relief in the installation. Secure the cables at regular intervals along their length as part of the installation to prevent cable wear and eliminate strain on the connectors. Damage to the connector interface or cable may result in hardware failure.

CAUTION: Ensure you maintain an acceptable cable bend radius, otherwise, you could damage the cable or the hardware.

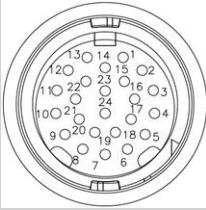
The cable harness (p/n ST101400-001) is IP67 when mated and about 3 m (10 ft.) in length.

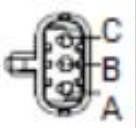

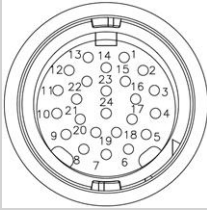
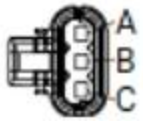
			
1 - Cable Connector Face	2 - Power Source	3 - COM1 Recorder	4 - COM3 Reefer
PIN 1 – ANA DIG to Sensor 2	-	-	-
PIN 2 – ANA DIG to Sensor 6	-	-	-
PIN 3 – ANA DIG to Sensor 8	-	-	-
PIN 4 – ANA DIG to Sensor 10	-	-	-
PIN 5 – OUTPUT (1 A maximum)	-	-	-
PIN 6 – GND	GND (Black)	Slot C (Black)	Slot C (Black)
PIN 7 – VEXT / Power	VEXT (Red)	-	-
PIN 8 – RS-232 Tx (Recorder)	-	Slot A (Green)	-
PIN 9 – RS-232 Tx / RS-485 P (Reefer)	-	-	Slot B (Green)
PIN 10 – CAN1 (-)	-	-	-
PIN 11 – GND	-	-	-
PIN 12 – CAN3 (+)	-	-	-
PIN 13 – 1-Wire DATA	-	-	-
PIN 14 – ANA DIG to Sensor 3	-	-	-
PIN 15 – ANA DIG to Sensor 5	-	-	-
PIN 16 – ANA DIG to Sensor 7	-	-	-
PIN 17 – 9 V/12 V (0.5 A maximum)	-	-	-
PIN 18 – ANA DIG to Sensor 9	-	-	-
PIN 19 – RS-232 Rx (Recorder)	-	Slot B (Red)	-
PIN 20 – RS-232 Rx (Reefer)	-	-	Slot A (Red)
PIN 21 – CAN1 (+)	-	-	-
PIN 22 – CAN3 (-)	-	-	-
PIN 23 – ANA DIG to Sensor 4	-	-	-
PIN 24 – ANA DIG to Sensor 1	-	-	-

			
Cable Connector Face	5 - CAN1/COM2	6 - CAN3	7
PIN 1 – ANA DIG to Sensor 2	-	-	-
PIN 2 – ANA DIG to Sensor 6	-	-	-
PIN 3 – ANA DIG to Sensor 8	-	-	-
PIN 4 – ANA DIG to Sensor 10	-	-	-
PIN 5 – OUTPUT (1 A maximum)	-	-	Alarm (Yellow)
PIN 6 – GND	Slot C (Black)	Slot C (Black)	GND for 9/12 VDC Output (Brown)
PIN 7 – VEXT / Power	-	-	-
PIN 8 – RS-232 Tx (Recorder)	-	-	-
PIN 9 – RS-232 Tx / RS-485 P (Reefer)	-	-	-
PIN 10 – CAN1 (-)	Slot B (Green)	-	-
PIN 11 – GND	-	-	-
PIN 12 – CAN3 (+)	-	Slot A (Green)	-
PIN 13 – 1-Wire DATA	-	-	DO NOT USE (Red)
PIN 14 – ANA DIG to Sensor 3	-	-	-
PIN 15 – ANA DIG to Sensor 5	-	-	-
PIN 16 – ANA DIG to Sensor 7	-	-	-
PIN 17 – 9 V/12 V (0.5 A maximum)	-	-	9/12 VDC Output (Black)
PIN 18 – ANA DIG to Sensor 9	-	-	-
PIN 19 – RS-232 Rx (Recorder)	-	-	-
PIN 20 – RS-232 Rx / RS-485 N (Reefer)	-	-	-
PIN 21 – CAN1 (+)	Slot A (Red)	-	-
PIN 22 – CAN3 (-)	-	Slot B (Red)	-
PIN 23 – ANA DIG to Sensor 4	-	-	-
PIN 24 – ANA DIG to Sensor 1	-	-	-

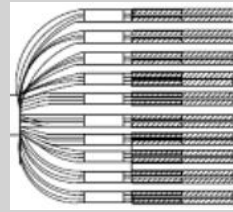
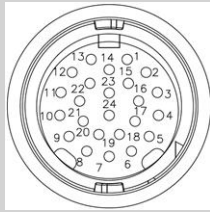

Cable Connector Face	8 - Sensor 1 to Sensor 10	GROUND
PIN 1 – ANA DIG to Sensor 2	Sensor 2 (Gray)	Gray / White
PIN 2 – ANA DIG to Sensor 6	Sensor 6 (Yellow)	Yellow / Black
PIN 3 – ANA DIG to Sensor 8	Sensor 8 (Red)	Red /White
PIN 4 – ANA DIG to Sensor 10	Sensor 10 (Black)	Black /White
PIN 5 – OUTPUT (1 A maximum)	-	-
PIN 6 – GND	Refer to GROUND column for color details	-
PIN 7 – VEXT / Power	-	-
PIN 8 – RS-232 Tx (Recorder)	-	-
PIN 9 – RS-232 Tx / RS-485 P (Reefer)	-	-
PIN 10 – CAN1 (-)	-	-
PIN 11 – empty	-	-
PIN 12 – CAN3 (+)	-	-
PIN 13 – 1-Wire DATA	-	-
PIN 14 – ANA DIG to Sensor 3	Sensor 3 (Purple)	Purple / White
PIN 15 – ANA DIG to Sensor 5	Sensor 5 (Green)	Green / White
PIN 16 – ANA DIG to Sensor 7	Sensor 7 (Orange)	Orange / White
PIN 17 – 9 V/12 V (0.5 A maximum)	-	-
PIN 18 – ANA DIG to Sensor 9	Sensor 9 (Brown)	Brown / White
PIN 19 – RS-232 Rx (Recorder)	-	-
PIN 20 – RS-232 Rx / RS-485 N (Reefer)	-	-
PIN 21 – CAN1 (+)	-	-
PIN 22 – CAN3 (-)	-	-
PIN 23 – ANA DIG to Sensor 4	Sensor 4 (Blue)	Blue / White
PIN 24 – ANA DIG to Sensor 1	Sensor 1 (White)	Orange / Black

APPENDIX G RT 8000 UNIVERSAL HARNESS

The RT 8000 Universal Harness (p/n ST101630-001) has an IP67 rating when mated with the RT 8000. It is 1.5 m (5 ft.) in length.

This cable facilitates the Euroscan MX2 to RT 8000 conversion and is ideal for new RT 8000 installations.

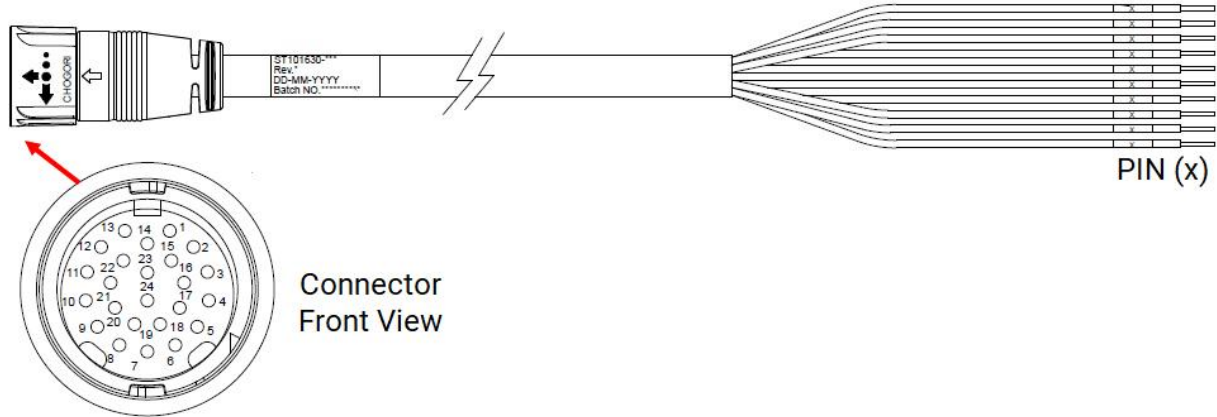

PIN (x)	Color	Function
7	Red	12 V Power
6	Black	Ground
	Orange	Door-
16	Gray	Door+
20	Blue	Reefer Rx
9	Pink	Reefer Tx
19	Brown	Recorder Rx
8	White	Recorder Tx
1	Green	Sensor 2
24	Yellow	Sensor 1